

## User's Manual



**RGB 190F**  
**RGB 192**  
**RGB 198**

**Analog Computer-Video Interface**

68-647-01 Rev. D

05 06



www.extron.com

**Extron Electronics, USA**

1230 South Lewis Street  
Anaheim, CA 92805  
USA  
714.491.1500  
Fax 714.491.1517

**Extron Electronics, Europe**

Beeldschemweg 6C  
3821 AH Amersfoort  
The Netherlands  
+31.33.453.4040  
Fax +31.33.453.4050

**Extron Electronics, Asia**

135 Joo Seng Road, #04-01  
PM Industrial Building  
Singapore 368363  
+65.6383.4400  
Fax +65.6383.4664

**Extron Electronics, Japan**

Kyodo Building  
16 Ichibancho  
Chiyoda-ku, Tokyo 102-0082 Japan  
+81.3.3511.7655  
Fax +81.3.3511.7656

# Precautions

## Safety Instructions • English



This symbol is intended to alert the user of important operating and maintenance (servicing) instructions in the literature provided with the equipment.



This symbol is intended to alert the user of the presence of uninsulated dangerous voltage within the product's enclosure that may present a risk of electric shock.

## Caution

**Read Instructions** • Read and understand all safety and operating instructions before using the equipment.

**Retain Instructions** • The safety instructions should be kept for future reference.

**Follow Warnings** • Follow all warnings and instructions marked on the equipment or in the user information.

**Avoid Attachments** • Do not use tools or attachments that are not recommended by the equipment manufacturer because they may be hazardous.

## Consignes de Sécurité • Français



Ce symbole sert à avertir l'utilisateur que la documentation fournie avec le matériel contient des instructions importantes concernant l'exploitation et la maintenance (réparation).



Ce symbole sert à avertir l'utilisateur de la présence dans le boîtier de l'appareil de tensions dangereuses non isolées posant des risques d'électrocution.

## Attention

**Lire les instructions** • Prendre connaissance de toutes les consignes de sécurité et d'exploitation avant d'utiliser le matériel.

**Conservier les instructions** • Ranger les consignes de sécurité afin de pouvoir les consulter à l'avenir.

**Respecter les avertissements** • Observer tous les avertissements et consignes marqués sur le matériel ou présentés dans la documentation utilisateur.

**Eviter les pièces de fixation** • Ne pas utiliser de pièces de fixation ni d'outils non recommandés par le fabricant du matériel car cela risquerait de poser certains dangers.

## Sicherheitsanleitungen • Deutsch



Dieses Symbol soll dem Benutzer in der im Lieferumfang enthaltenen Dokumentation besonders wichtige Hinweise zur Bedienung und Wartung (Instandhaltung) geben.



Dieses Symbol soll den Benutzer darauf aufmerksam machen, daß im Inneren des Gehäuses dieses Produktes gefährliche Spannungen, die nicht isoliert sind und die einen elektrischen Schock verursachen können, herrschen.

## Achtung

**Lesen der Anleitungen** • Bevor Sie das Gerät zum ersten Mal verwenden, sollten Sie alle Sicherheits- und Bedienungsanleitungen genau durchlesen und verstehen.

**Aufbewahren der Anleitungen** • Die Hinweise zur elektrischen Sicherheit des Produktes sollten Sie aufbewahren, damit Sie im Bedarfsfall darauf zurückgreifen können.

**Befolgen der Warnhinweise** • Befolgen Sie alle Warnhinweise und Anleitungen auf dem Gerät oder in der Benutzerdokumentation.

**Keine Zusatzgeräte** • Verwenden Sie keine Werkzeuge oder Zusatzgeräte, die nicht ausdrücklich vom Hersteller empfohlen wurden, da diese eine Gefahrenquelle darstellen können.

## Instrucciones de seguridad • Español



Este símbolo se utiliza para advertir al usuario sobre instrucciones importantes de operación y mantenimiento (o cambio de partes) que se desean destacar en el contenido de la documentación suministrada con los equipos.



Este símbolo se utiliza para advertir al usuario sobre la presencia de elementos con voltaje peligroso sin protección aislante, que puedan encontrarse dentro de la caja o alojamiento del producto, y que puedan representar riesgo de electrocución.

## Precaución

**Leer las instrucciones** • Leer y analizar todas las instrucciones de operación y seguridad, antes de usar el equipo.

**Conservar las instrucciones** • Conservar las instrucciones de seguridad para futura consulta.

**Obedecer las advertencias** • Todas las advertencias e instrucciones marcadas en el equipo o en la documentación del usuario, deben ser obedecidas.

**Evitar el uso de accesorios** • No usar herramientas o accesorios que no sean específicamente recomendados por el fabricante, ya que podrían implicar riesgos.

## Warning

**Power sources** • This equipment should be operated only from the power source indicated on the product. This equipment is intended to be used with a main power system with a grounded (neutral) conductor. The third (grounding) pin is a safety feature, do not attempt to bypass or disable it.

**Power disconnection** • To remove power from the equipment safely, remove all power cords from the rear of the equipment, or the desktop power module (if detachable), or from the power source receptacle (wall plug).

**Power cord protection** • Power cords should be routed so that they are not likely to be stepped on or pinched by items placed upon or against them.

**Servicing** • Refer all servicing to qualified service personnel. There are no user-serviceable parts inside. To prevent the risk of shock, do not attempt to service this equipment yourself because opening or removing covers may expose you to dangerous voltage or other hazards.

**Slots and openings** • If the equipment has slots or holes in the enclosure, these are provided to prevent overheating of sensitive components inside. These openings must never be blocked by other objects.

**Lithium battery** • There is a danger of explosion if battery is incorrectly replaced. Replace it only with the same or equivalent type recommended by the manufacturer. Dispose of used batteries according to the manufacturer's instructions.

## Avertissement

**Alimentations** • Ne faire fonctionner ce matériel qu'avec la source d'alimentation indiquée sur l'appareil. Ce matériel doit être utilisé avec une alimentation principale comportant un fil de terre (neutre). Le troisième contact (de mise à la terre) constitue un dispositif de sécurité : n'essayez pas de le contourner ni de le désactiver.

**Déconnexion de l'alimentation** • Pour mettre le matériel hors tension sans danger, déconnectez tous les cordons d'alimentation de l'arrière de l'appareil ou du module d'alimentation de bureau (s'il est amovible) ou encore de la prise secteur.

**Protection du cordon d'alimentation** • Acheminer les cordons d'alimentation de manière à ce que personne ne risque de marcher dessus et à ce qu'ils ne soient pas écrasés ou pincés par des objets.

**Réparation-maintenance** • Faire exécuter toutes les interventions de réparation-maintenance par un technicien qualifié. Aucun des éléments internes ne peut être réparé par l'utilisateur. Afin d'éviter tout danger d'électrocution, l'utilisateur ne doit pas essayer de procéder lui-même à des opérations car l'ouverture ou le retrait des couvercles risquent de l'exposer à de hautes tensions et autres dangers.

**Fentes et orifices** • Si le boîtier de l'appareil comporte des fentes ou des orifices, ceux-ci servent à empêcher les composants internes sensibles de surchauffer. Ces ouvertures ne doivent jamais être bloquées par des objets.

**Lithium Batterie** • Il a danger d'explosion s'il y a remplacement incorrect de la batterie. Remplacer uniquement avec une batterie du même type ou d'un type équivalent recommandé par le constructeur. Mettre au reut les batteries usagées conformément aux instructions du fabricant.

## Vorsicht

**Stromquellen** • Dieses Gerät sollte nur über die auf dem Produkt angegebene Stromquelle betrieben werden. Dieses Gerät wurde für eine Verwendung mit einer Hauptstromleitung mit einem geerdeten (neutralen) Leiter konzipiert. Der dritte Kontakt ist für einen Erdschluss, und stellt eine Sicherheitsfunktion dar. Diese sollte nicht umgangen oder außer Betrieb gesetzt werden.

**Stromunterbrechung** • Um das Gerät auf sichere Weise vom Netz zu trennen, sollten Sie alle Netzkabel aus der Rückseite des Gerätes, aus der externen Stromversorgung (falls dies möglich ist) oder aus der Wandsteckdose ziehen.

**Schutz des Netzkabels** • Netzkabel sollten stets so verlegt werden, daß sie nicht im Weg liegen und niemand darauf treten kann oder Objekte darauf- oder unmittelbar dagegestellt werden können.

**Wartung** • Alle Wartungsmaßnahmen sollten nur von qualifiziertem Servicepersonal durchgeführt werden. Die internen Komponenten des Gerätes sind wartungsfrei. Zur Vermeidung eines elektrischen Schocks versuchen Sie in keinem Fall, dieses Gerät selbst öffnen, da beim Entlernen der Abdeckungen die Gefahr eines elektrischen Schlags und/oder andere Gefahren bestehen.

**Schlitzte und Öffnungen** • Wenn das Gerät Schlitzte oder Löcher im Gehäuse aufweist, dienen diese zur Vermeidung einer Überhitzung der empfindlichen Teile im Inneren. Diese Öffnungen dürfen niemals von anderen Objekten blockiert werden.

**Litium-Batterie** • Explosionsgefahr, falls die Batterie nicht richtig ersetzt wird. Ersetzen Sie verbrauchte Batterien nur durch den gleichen oder einen vergleichbaren Batterietyp, der auch vom Hersteller empfohlen wird. Entsorgen Sie verbrauchte Batterien bitte gemäß den Herstelleranweisungen.

## Advertencia

**Alimentación eléctrica** • Este equipo debe conectarse únicamente a la fuente/tipo de alimentación eléctrica indicada en el mismo. La alimentación eléctrica de este equipo debe provenir de un sistema de distribución general con conductor neutro a tierra. La tercera pata (puesta a tierra) es una medida de seguridad, no puede ser eliminada.

**Desconexión de alimentación eléctrica** • Para desconectar con seguridad la acometida de alimentación eléctrica al equipo, desenchufar todos los cables de alimentación en el panel trasero del equipo, o desenchufar el módulo de alimentación (si fuera independiente), o desenchufar el cable del receptáculo de la pared.

**Protección del cables de alimentación** • Los cables de alimentación eléctrica se deben instalar en lugares donde no sean pisados ni apretados por objetos que se puedan apoyar sobre ellos.

**Reparaciones/mantenimiento** • Solicitar siempre los servicios técnicos de personal calificado. En el interior no hay partes a las que el usuario deba acceder. Para evitar riesgo de electrocución, no intentar personalmente la reparación/ mantenimiento de este equipo, ya que al abrir o extraer las tapas puede quedar expuesto a voltajes peligrosos u otros riesgos.

**Ranuras y aberturas** • Si el equipo posee ranuras o orificios en su caja/alojamiento, es para evitar el sobrecalentamiento de componentes internos sensibles. Estas aberturas nunca se deben obstruir con otros objetos.

**Batería de litio** • Existe riesgo de explosión si esta batería se coloca en la posición incorrecta. Cambiar esta batería únicamente con el mismo tipo (o su equivalente) recomendado por el fabricante. Desachar las baterías usadas siguiendo las instrucciones del fabricante.

# FCC Class A Notice

Note: This equipment has been tested and found to comply with the limits for a Class A digital device, pursuant to part 15 of the FCC Rules. These limits are designed to provide reasonable protection against harmful interference when the equipment is operated in a commercial environment. This equipment generates, uses and can radiate radio frequency energy and, if not installed and used in accordance with the instruction manual, may cause harmful interference to radio communications. Operation of this equipment in a residential area is likely to cause harmful interference, in which case the user will be required to correct the interference at his own expense.

Note: This unit was tested with shielded cables on the peripheral devices. Shielded cables must be used with the unit to ensure compliance.

# Extron's Warranty

Extron Electronics warrants this product against defects in materials and workmanship for a period of three years from the date of purchase. In the event of malfunction during the warranty period attributable directly to faulty workmanship and/or materials, Extron Electronics will, at its option, repair or replace said products or components, to whatever extent it shall deem necessary to restore said product to proper operating condition, provided that it is returned within the warranty period, with proof of purchase and description of malfunction to:

## USA, Canada, South America, and Central America:

Extron Electronics  
1001 East Ball Rd.  
Anaheim, CA 92805, USA

## Asia:

Extron Electronics, Asia  
135 Joo Seng Road, #04-01  
PM Industrial Bldg.  
Singapore 368363

## Europe, Africa, and the Middle East:

Extron Electronics, Europe  
Beeldschermweg 6C  
3821 AH Amersfoort  
The Netherlands

## Japan:

Extron Electronics, Japan  
Kyoko Building  
16 Ichibancho  
Chiyoda-ku, Tokyo 102-0082  
Japan

This Limited Warranty does not apply if the fault has been caused by misuse, improper handling care, electrical or mechanical abuse, abnormal operating conditions or non-Extron authorized modification to the product.

*If it has been determined that the product is defective, please call Extron and ask for an Applications Engineer at (714) 491-1500 (USA), 31.33.453.4040 (Europe), 65.6383.4400 (Asia), or 81.3.3511.7655 (Japan) to receive an RA# (Return Authorization number). This will begin the repair process as quickly as possible.*

Units must be returned insured, with shipping charges prepaid. If not insured, you assume the risk of loss or damage during shipment. Returned units must include the serial number and a description of the problem, as well as the name of the person to contact in case there are any questions.

Extron Electronics makes no further warranties either expressed or implied with respect to the product and its quality, performance, merchantability, or fitness for any particular use. In no event will Extron Electronics be liable for direct, indirect, or consequential damages resulting from any defect in this product even if Extron Electronics has been advised of such damage.

Please note that laws vary from state to state and country to country, and that some provisions of this warranty may not apply to you.

## 安全须知 • 中文



这个符号提示用户该设备用户手册中的操作和维护说明。



这个符号警告用户该设备机壳内暴露的危险电压，有触电危险。

### 注意

**阅读说明书** • 用户使用该设备前必须阅读并理解有安全和使用说明。

**保存说明书** • 用户应保存安全说明书以备将来使用。  
**遵守警告** • 用户应遵守产品和用户指南上的所有安全和操作说明。

**避免追加** • 不要使用该产品厂商没有推荐的工具或追加设备，以避免危险。

### 警告

**电源** • 该设备只能使用产品上标明的电源。设备必用有地线供电系统供电。第三条线（地线）是安设施，不能不用或跳过。

**拔掉电源** • 为安全地从设备拔掉电源，请拔掉所有后备或桌面电源的电源线，或任何接到市电系统电源线。

**电源线保护** • 妥善布线，避免被踩踏，或重物挤压。

**维护** • 所有维修必须由认证的维修人员进行。设备部没有用户可以更换的零件。为避免出现触电危险不要自己试图打开设备盖子维修该设备。

**通风孔** • 有些设备机壳上有通风槽或孔，它们是用防止机内敏感元件过热。不要用任何东西挡住通风孔。

**锂电池** • 不正确的更换电池会有爆炸的危险。必须使与厂家推荐的相同或相近型号的电池。按照生产厂的议处理废弃电池。

# Table of Contents

---

<b>Chapter 1 • Introduction</b> .....	1-1
<b>About this Manual</b> .....	1-2
<b>About the RGB 190F, RGB 192, and RGB 198</b> .....	1-2
<b>Features</b> .....	1-3
<b>Chapter 2 • Installation and Operation</b> .....	2-1
<b>Installation Overview</b> .....	2-2
<b>Mounting the Interfaces</b> .....	2-2
Tabletop placement .....	2-2
Under-desk mounting .....	2-2
Through-desk mounting .....	2-3
Rack mounting (RGB 198 only) .....	2-4
<b>Connections and Switches</b> .....	2-5
<b>Operation and Troubleshooting</b> .....	2-10
If the image does not appear or there is no sound .....	2-10
If the image is not displayed correctly .....	2-11
If the interface does not respond to controls .....	2-11
<b>Appendix • Reference Information</b> .....	A-1
<b>Specifications</b> .....	A-2
<b>Included Parts</b> .....	A-5
<b>Optional Accessories</b> .....	A-6
<b>Cables</b> .....	A-7



## RGB 190F, RGB 192, and RGB 198

# Chapter One

## Introduction

About this Manual

About the RGB 190F, RGB 192, and RGB 198

Features

68-647-01  
Rev. D  
05 06

*All trademarks mentioned in this manual are the properties of their respective owners.*

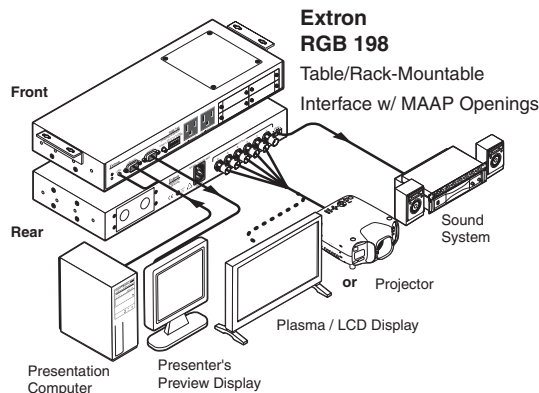
# Introduction

## About this Manual

This manual contains information about the Extron RGB 190F, RGB 192, and RGB 198 universal interfaces, detailing how to operate and configure them. The three interfaces are functionally identical, with the exception of the audio capabilities of the RGB 192 and RGB 198. All interfaces are described in this manual; differences are noted where they exist.

## About the RGB 190F, RGB 192 and RGB 198

The RGB 190F, RGB 192, and RGB 198 are analog computer-video interfaces with 300 MHz (-3 dB) video bandwidth and Digital Display Sync Processing™ (DDSP™). Figure 1-1 shows a typical RGB 198 application; as noted above, the RGB 190F and the RGB 192 have a similar setup. The interfaces accept a computer video and an unbalanced computer stereo audio input. They feature a local monitor output and an RGBHV, RGsB or RGSb output. The interfaces feature horizontal centering and level boost. The RGB 192 and RGB 198 also feature a balanced, line level stereo or mono audio output.



**Figure 1-1 — Typical RGB 198 application**

All three interfaces allow for furniture and under-desk mounting. The RGB 198 is rack mountable as well. The RGB 190F and RGB 192 have external switching power supplies for worldwide power compatibility, while the RGB 198 provides an internal power supply.

Each RGB interface has two or more model options:

### Three RGB 190F models

- RGB 190FV for PC computers
- RGB 190FM for Macintosh computers
- RGB 190FS for SGI computers

### Two RGB 192 models

- RGB 192V for PC computers
- RGB 192S for SGI computers

These two models are otherwise identical with the exception of the video input cable supplied.

### Two RGB 198 models

- The RGB 198 provides an AC outlet with two Edison plugs.
- The RGB 198 EU provides an AC outlet with two Euro plugs for European markets.

With the appropriate cable adapters, both of these models are compatible with Macintosh computer and SGI computers.

## Features

**Flexible mounting options** — The interface can be mounted under a desk or podium, mounted on a rack (RGB 198 only), or through a desk with optional mounting kits.

**Stereo audio (RGB 192 and 198 only)** — The interface outputs unbalanced PC stereo audio as line level, balanced stereo (or, depending on a DIP switch position, mono).

**Level (boost) control** — A front panel control compensates for signal losses from long cable runs.

**Horizontal centering control** — A front panel control allows a horizontal centering adjustment.

**Sync processing** — Using regular sync processing to allow centering control (H-shift) can create problems with some digital display devices as a result of the sync delay. Extron's DDSP (Digital Display Sync Processing), ensures proper displays without altering sync pulse timing or width. The sync processing type is selected via the front panel DIP switches.

## Introduction, cont'd

---

**RGBHV, RGBS, or RGSB outputs** — Select the output format via cabling setup and front panel DIP switch.

**Serration pulse switch** — This DIP switch-selectable feature adds or strips the serration pulses from the output signal to make it compatible with digital display devices. Use the serration pulse switch if flagging or bending occurs at the top of the video display.



## RGB 190F, RGB 192, and 198

# Chapter Two

## Installation and Operation

Installation Overview

Mounting the Interfaces

Connections and Switches

Operation and Troubleshooting

# Installation and Operation

## Installation Overview

This is an overview of the installation process. You will find detailed installation and operation instructions in this chapter.

Install and set up the RGB 190F, RGB 192, or RGB 198 interfaces by following these basic steps:

- 1 Turn off all of the equipment (computers, remote controls, interface, projector/monitor, local monitor and speakers or other audio device). Disconnect the power cords from the power source.
- 2 Install the rubber feet for tabletop use, or install the appropriate brackets to rack mount the interface. See *Mounting the Interfaces* below.
- 3 Connect the input (computer video and audio [RGB 192 and 198 only]) and outputs (display, local monitor, and audio [RGB 192 and 198 only]). See *Connections and Switches* in this chapter.
- 4 Set the front panel DIP switches. See *Connections and Switches*, in this chapter, as a guide.
- 5 Connect power cords and turn on the devices: output devices (projector, monitors, speakers [RGB 192 and 198 only]), interface, and the source computer.
- 6 Adjust horizontal centering and set the Level DIP switch to obtain the best picture.

## Mounting the Interfaces

The interfaces provide several mounting options: tabletop placement, under-desk mounting, through-desk mounting or (for the RGB 198 only) rack mounting. Follow the appropriate procedure on the next three pages.

### Tabletop placement

For tabletop or desktop placement only, install the self-adhesive rubber feet/pads (provided) onto the four corners of the bottom of the interface enclosure.

### Under-desk mounting

- 1 Secure the included under-desk mounting brackets (part #70-077-01) to the interface with the machine screws that are already installed in the side of the interface (figure 2-1).

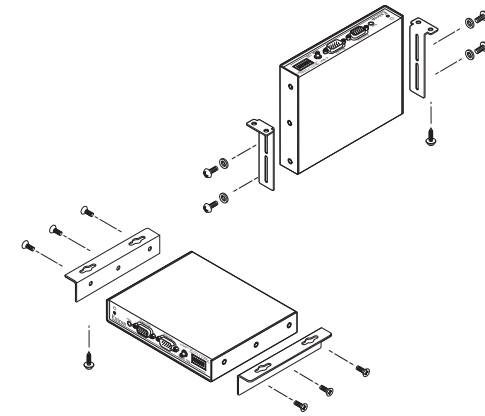


Figure 2-1 — Under-desk mounting

- 2 Hold the interface with attached brackets against the underside of the desk or other furniture. Mark the location of holes for screws on the desk.
- 3 Drill pilot holes 1/4" (6.4 mm) deep, and 3/32" (2 mm) diameter in the table or desk at the marked screw locations from the underside/inside (concealed side) of the furniture, where the interface will be located.
- 4 Insert the four wood screws into the pilot holes. Fasten each screw into the installation surface until just less than 1/4" of the screw protrudes.
- 5 Align the installed screws with the slots in the mounting brackets, and place the interface against the surface, with the screws through the bracket slots.
- 6 Slide the interface slightly forward or back, then tighten all four screws to fasten it in place.

### Through-desk mounting

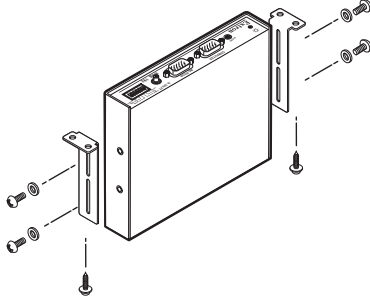
- 1 If rubber feet were installed on the interface, remove them.
- 2 Insert the machine screws that are already installed in the side of the interface through the slots in the through-desk mounting brackets (part #70-077-02), and loosely secure the brackets to the interface (figure 2-2).

## Installation and Operation, cont'd

- Hold the interface with attached brackets against the underside of the desk/table. With a soft pencil mark the location of holes for screws on the desk based on the following:

For the **RGB 190 and RGB 192**, mark the opening approximately 1.0" x 5.7" (2.5 cm x 14.5 cm).

For the **RGB 198**, mark the opening approximately 1.75" x 13.0" (4.5 cm x 33.0 cm).

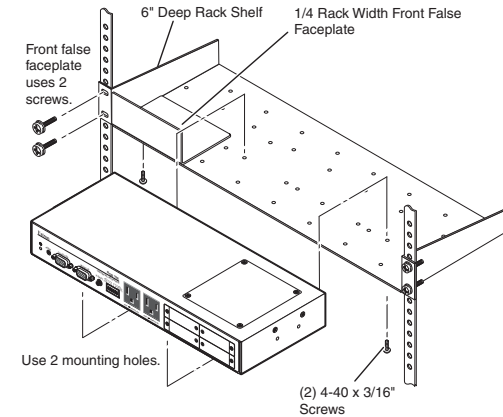


**Figure 2-2 — Through-desk mounting**

- Cut out the material from the installation area with a jigsaw. Check the opening size by inserting the interface part way through the hole. If needed, use a saw, file or sandpaper to enlarge the hole. Smooth the edges of the hole with sandpaper.
- Drill pilot holes 1/4" (6.4 mm) deep, and 3/32" (2 mm) diameter in the underside or inside (concealed side) of the furniture where the interface will be located.
- Secure the interface to the desk with the provided wood screws.
- To adjust the height of the interface within the desk, slide the interface up or down to the desired position, then tighten the screws that attach the brackets to the interface.

### Rack mounting (RGB 198 only)

- Remove rubber feet if they were previously installed on the bottom of the interface.
- Mount the interface on either side of an 19" 1U Universal Rack Shelf (part # 60-190-01) using two 4-40 x 3/16" screws to secure it to the shelf. See figure 2-3.
- Install blank panel(s) or other unit(s) on the rack shelf.
- Attach the rack shelf to the rack using the supplied bolts.



**Figure 2-3 — Rack mounting**

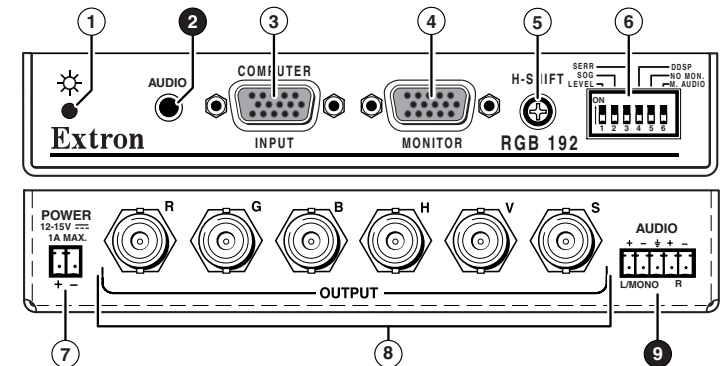
## Connections and Switches

Figures 2-4 and 2-5 show the front and rear panel of the RGB 192 and the RGB 198, respectively. With the exception of audio features (numbers 2 and 9), all numbers for figure 2-4 pertain to both the RGB 190 and 192 models.

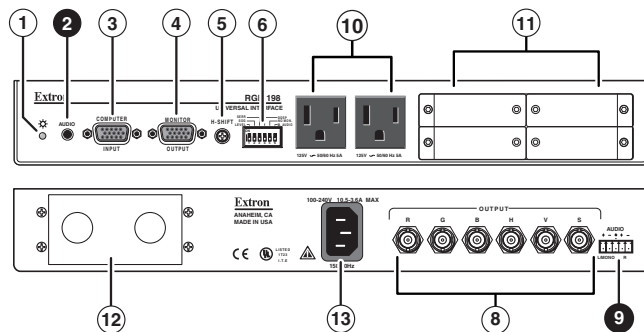
### 1 Power indicator —

**Amber** — Indicates power is applied.

**Green** — Indicates that power is applied and a sync signal is present on the input.

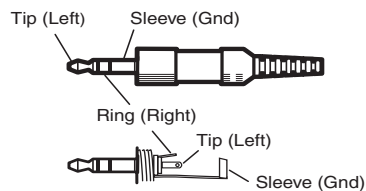


**Figure 2-4 — RGB 192 front and rear panel features**



**Figure 2-5 — RGB 198 front and rear panel features**

- 2 Audio input (RGB 192 and 198 only)** — Connect the unbalanced stereo audio source (such as a computer or a CD player) to this 3.5 mm mini stereo jack for unbalanced audio input. Figure 2-6 shows how to wire the audio jack.



**Figure 2-6 — Audio input connector wiring**

- 3 Computer Input** — Connect the analog computer-video source to this 15-pin HD female connector.

**NOTE** Most laptop or notebook computers have an external video port, but they require special commands to output the video to that connector. Also, laptops' screens shut off once that port is activated. See the computer's user's guide for details, or contact Extron for a list of laptop keyboard commands.

- 4 Monitor Output** — If desired, connect a local monitor or other device to this 15-pin HD female connector.
- 5 H(orizontal) Shift** — While viewing the displayed image, rotate this control to move the image to the right or left on the screen.

**NOTE** DDSP disables the interface's Horizontal Shift control.  
To use the display's centering controls instead of the interface's controls, set the DDSP DIP switch to On.

- 6 DIP switches** — This bank of DIP switches is used to configure the interface. The switches control:

- Level
- SOG (sync on green)
- Serration pulses
- DDSP
- Monitor or no monitor (ID bit termination)
- Mono or stereo audio (RGB 192 and 198 only, spare on RGB 190F)

**NOTE** The default for all DIP switches is Off (down).

**1 — Level (and peaking)**

The Level control alters the video output voltage to affect the brightness of the displayed image. Turn the switch on and off while viewing the displayed image to set the level that provides the best picture quality. If the interface receives a typical (0.7 volts p-p) analog computer video input, the output is as follows:

- On — 0.8 volts p-p with peaking
- Off — 0.7 volts p-p

**2 — Sync on green**

- On — The interface outputs a composite sync signal on top of the green video signal (SOG) via the G output connector (RGsB).
- Off — The interface outputs separate horizontal and vertical sync (on the H and V connectors) and composite sync (on the S connector) for RGBHV or RGBS.

**3 — Serration pulses** — Many LCD and DLP projectors and plasma displays do not display properly if serration pulses are present in the sync signal. Flagging or bending at the top of the video image is a sign that the serration pulses should be removed.

- On — The interface outputs serration pulses in the vertical sync interval.
- Off — The interface does not output serration pulses.

## 4 — DDSP

DDSP disables all sync processing. This feature may be necessary for digital display devices such as LCD, DLP (digital light processor) and plasma displays. Use this option if the image is not displayed properly after other options, such as serration pulse and video termination changes, have been tried.

**On** — The interface uses DDSP, which does not process the sync signal.

**NOTE** *DDSP disables the horizontal and vertical centering controls.*

**Off** — The interface performs sync processing operations.

## 5 — No monitor (ID bit termination) — This switch controls the input assigned to the local monitor output and ID bit termination.

**On** — ID bits 4 and 11 are tied to ground.

**Off** — ID bits 4 and 11 are unterminated.

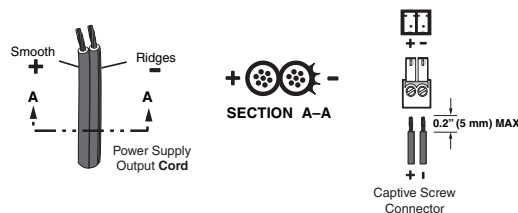
## 6 — Mono audio output (RGB 192 only, spare on RGB 190F)

**On** — Monaural audio is output on the left channel only. When mono is selected, the right and left inputs are combined and placed on the left output connectors.

**Off** — Normal stereo output.

## 7 Power connector — Plug the external 12 V power supply into this 2-pole captive screw connector. The power supply is included with the unit. Figure 2-7 shows how to wire the connector.

**NOTE** *Do not tin the stripped power supply leads before installing the captive screw connector. Tinned wires are not as secure in the captive screw connectors and could pull out.*



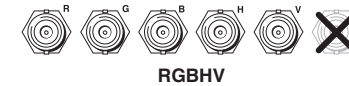
**Figure 2-7 — Power connector wiring**

**WARNING** *The two power cord wires must be kept separate while the power supply is plugged in. Remove power before continuing.*

To verify the polarity before connection, check the no-load power supply output with a voltmeter.

## 8 BNC output connectors — Connect a coaxial cable between the display (projector or monitor) and these rear panel BNC connectors.

For RGBHV (**separate H and V sync**) output, connect the cables to five BNCs.



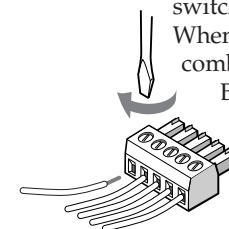
For RGBS (**composite sync**), connect the cables to four BNCs.



For RGSB (**sync on green, SOG**), connect the cables to three BNCs. Also select the SOG option on the front panel DIP switch (see item 6, *Dip switches*, in this chapter).



## 9 Stereo audio output connector (RGB 192 and 198 only) — Connect an audio device, such as powered speakers, to this 3.5 mm, 5-pole captive screw connector for balanced or unbalanced stereo or mono audio output. Stereo or mono output is determined by a DIP switch setting on the front panel. See DIP switch 6 in item 6, *DIP switches*, on the previous page.



When mono is selected, the right and left inputs are combined and placed on the left output connectors. Balanced or unbalanced outputs are available for mono and stereo.

The illustration here shows how to wire the captive screw audio connector. The connector is included with the interface, but you must obtain the cable. Insert the wires into the appropriate openings in the captive screw connector. Tighten the screws on top to fasten the wires.

**CAUTION** Wiring the audio incorrectly can damage the audio output circuits.

Connect the sleeve(s) to ground (GND).  
Connecting the sleeve(s) to a negative (-) terminal will damage audio output circuits.



Unbalanced Output

Balanced Output

**Figure 2-8 — Wiring the audio output connector**

- ⑩ **Unswitched AC outlets** — These AC outlets are available in an Edison or Euro plug.
- ⑪ **MAAP openings** — Two double MAAP openings, one adjacent to the other, allow up to four single-sized MAAP pass through audio and video connectors.
- ⑫ **Double AAP openings** — This plate allows easy access to the back of the MAAPs while safely isolating the power supply and interface.
- ⑬ **IEC AC power plug** — Provides convenient power input.

## Operation and Troubleshooting

Connect the power cords and turn on the displays (projectors or monitors), audio output devices (sound system – **RGB 192 and 198 only**), the interface and the input device (computer). The image should appear on screen, and sound should be audible (**RGB 192 and 198 only**). If not, ensure that all devices are plugged in and receiving power. Check the cabling and switch settings, and make adjustments as needed.

### If the image does not appear or there is no sound

1. Ensure that all devices are plugged in.
2. Make sure that each device is receiving power. The interface's front panel LED lights green if the interface is receiving power and an active sync signal.
3. Check the cabling and the audio connector wiring and grounding, and make adjustments as needed.

4. For digital display devices (including LCD, DLP and plasma devices), try turning the DDSP DIP switch (switch 4) On (up) or Off (down) on the front panel.
5. To test the system setup and output, substitute a video test generator for the computer input. Unplug the input and output devices' and the interface's power cords, replace the video source with a VTG, then reconnect power cords to restore AC power.
6. Call the Extron S<sup>3</sup> Sales & Technical Support Hotline if needed.

### If the image is not displayed correctly

- If the output image looks too green, the sync on green (SOG) DIP switch (switch 2) may be set to On (up), and the display device may not be configured to handle SOG signals. Set the switch to Off (down).
- If the picture bends or flags at the top of the screen, set the serration pulse DIP switch (switch 3) to Off (down).
- For a display device that experiences intermittent glitches, try turning DDSP On (up) or Off (down) using DIP switch 1 on the front panel.
- If the picture hangs off the edge of the screen, adjust the Horizontal Shift control.
- If the edges of the image seem to exceed their boundaries or if thin lines and sharp edges look thick and fuzzy, try changing the Level DIP switch (switch 1) to On (up). If the image is too bright, turn the Level switch to Off (down).
- If the image still does not display correctly, call the Extron S<sup>3</sup> Sales & Technical Support Hotline.

### If the interface does not respond to controls

If the picture does not move on screen when the horizontal shift control is rotated, DDSP is in use. Set the DDSP DIP switch (switch 4) on the front panel to Off (down).



# A

## **Appendix A**

### **Reference Information**

Specifications

Included Parts

Optional Accessories

Cables

# Reference Information

## Specifications

### Video

Gain .....	Unity (0.7 V), (0.8 V) 15% with 3 dB peaking
Bandwidth .....	300 MHz (-3 dB)
Max. rise/fall time .....	1.5 ns

### Video input and loop-through

Number/signal type .....	1 analog VGA-UXGA, Mac, Sun RGBHV, RGBS, RGsB 1 buffered local monitor loop-through identical to the input
Connectors .....	(1) female 15-pin HD (input) (1) female 15-pin HD (loop-through)
Nominal level .....	0.7 V p-p for RGB
Minimum/maximum levels .....	Analog: 0.3 V to 1.45 Vp-p with no offset at unity gain
Impedance .....	75 ohms
Horizontal frequency .....	15 kHz to 130 kHz
Vertical frequency .....	30 Hz to 170 Hz
Return loss .....	<-41 dB @ 5 MHz
DC offset (max. allowable) .....	4 V

### Video output

Number/signal type .....	1 RGBHV, RGBS, RGsB
Connectors .....	6 BNC female
Nominal level .....	0.7 Vp-p for RGB
Minimum/maximum levels .....	0.7 V to 0.8 Vp-p (switch selectable) with peaking
Impedance .....	75 ohms
Return loss .....	-45 dB @ 5 MHz
DC offset .....	±5 mV with input at 0 offset

### Sync

Input type .....	RGBHV, RGBS, RGsB (does not strip sync from video)
Output type .....	RGBHV at all times, RGBS at all times, RGsB (switch selectable)
Input level .....	2.0 V to 5.5 Vp-p with ±0.2 VDC offset (max.)
Output level .....	4.0 V to 5.0 Vp-p, unterminated

Input impedance .....	510 ohms
Output impedance .....	75 ohms
Max. propagation delay .....	57 ns
Max. rise/fall time .....	4 ns
Polarity .....	RGBHV input: positive or negative (follows input) RGBS, RGsB input: negative

### Audio — all models except RGB 190F

Gain .....	Unbalanced output: 0 dB; balanced output: +6 dB
Frequency response .....	20 Hz to 20 kHz, ±0.05 dB
THD + Noise .....	0.03% @ 1 kHz, 0.3% @ 20 kHz at nominal level
S/N .....	>90 dB at maximum output (14 dBm), balanced, unweighted
Crosstalk .....	<-90 dB @ 1 kHz
Stereo channel separation .....	>90 dB @ 1 kHz to 20 kHz

### Audio input — all models except RGB 190F

Number/signal type .....	1 stereo or mono, unbalanced
Connectors .....	(1) 3.5 mm mini stereo audio jack (tip, ring, sleeve)
Impedance .....	>10k ohms unbalanced, DC coupled
Nominal level .....	-10 dBV (316 mVrms, -7.78 dBu)
Maximum level .....	+9.5 dBu, (unbalanced) at 1% THD+N

**NOTE**  $0\text{ dBu} = 0.775\text{ Vrms}$ ,  $0\text{ dBV} = 1\text{ Vrms}$ ,  $0\text{ dBV} \approx 2\text{ dBu}$

### Audio output — all models except RGB 190F

Number/signal type .....	1 buffered stereo or mono, balanced/unbalanced
Connectors .....	(1) 3.5 mm captive screw connector, 5 pole
Impedance .....	50 ohms unbalanced, 100 ohms balanced
Gain error .....	±0.1 dB channel to channel
Maximum level (Hi-Z) .....	>+14 dBm, balanced at 1% THD+N
Maximum level (600 ohm) .....	>+9 dBm, balanced at 1% THD+N

### General

Power (RGB 198, RGB 198EU) ...	100 VAC to 240 VAC, 50/60 Hz, 15 watts, internal, autoswitchable
--------------------------------	--

## Reference Information, cont'd

External power supply (RGB 190F, RGB 192)	100 VAC to 240 VAC, 50/60 Hz, external, autoswitchable; to 12 VDC, 1 A, regulated, included
Power input requirements (RGB 190F, RGB 192)	12 VDC, 0.35 A
Temperature/humidity .....	Storage -40° to +158°F (-40° to +70°C) / 10% to 90%, noncondensing Operating +32° to +122°F (0° to +50°C) / 10% to 90%, noncondensing
Rack mount	
RGB 198, RGB 198EU .....	Yes, with optional 1U rack shelf, part #60-190-01 or 60-604-01 Also furniture mountable with kit #70-077-01 (included) or kit #70-077-02 (optional)
RGB 190F, RGB 192 .....	No, but furniture mountable with included under-desk mounting brackets
Enclosure type .....	Metal
Enclosure dimensions	
RGB 198, RGB 198EU .....	1.75" H x 13.0" W x 4.5" D (1U high, three quarters rack wide) 4.4 cm H x 32.7 cm W x 11.4 cm D (Depth excludes connectors.)
RGB 190F, RGB 192 .....	1.0" H x 5.7" W x 4.5" D 2.5 cm H x 14.5 cm W x 11.4 cm D (Depth excludes connectors.)
Product weight	
RGB 198, RGB 198EU .....	2.0 lbs (0.9 kg)
RGB 190F, RGB 192 .....	0.9 lbs (0.4 kg)
Shipping weight	
RGB 198, RGB 198EU .....	4 lbs (2 kg)
RGB 190F, RGB 192 .....	3 lbs (2 kg)
Vibration .....	ISTA 1A in carton (International Safe Transit Association)
Listings .....	UL, CUL
Compliances .....	CE, FCC Class A, VCCI, AS/NZS, ICES
MTBF .....	30,000 hours
Warranty .....	3 years parts and labor

**NOTE** All nominal levels are at  $\pm 10\%$ .

**NOTE** Specifications are subject to change without notice.

## Included Parts

Unless otherwise noted, these items are included in each order for an RGB 190F, RGB 192, or RGB 198:

Interface	Part number
RGB 190FV	60-486-61
VGA M 6' MHR (Molded)	26-238-01
RGB 190FM	60-486-62
Mac Adapter 15-HDM Kit with audio	70-156-01
RGB 190FS	60-486-63
13W3 Adapter 15-HDM Kit with audio	70-157-23
RGB 192V	60-486-01
VGAM 6' MHRA 15-pin HD Cable	26-490-02
RGB 192S	60-486-02
13W3 Adapter 15-HDM Kit with audio	70-157-03
RGB 198	60-673-02
RGB 198EU	60-674-02

## Reference Information, cont'd

Included items	Part number
Rubber feet	
IEC power cord	
Tweezer	
Universal 12VDC external power supply (RGB 190 and RGB 192 only)	70-055-01
Under-desk mounting kit instruction card	68-461-01
3.5 mm, 5-pole captive screw connector	10-319-10
Under-desk mounting bracket kit	70-077-01
3/32 Hex wrench (RGB 198 only)	100-012-01
MAAP single blank (black) (RGB 198 only)	70-315-11
MAAP double blank (black) (RGB 198 only)	70-315-12
Two Cable Clamp/Pass-Through (Black) (RGB 198 only)	70-127-01
<i>RGB 190F, RGB 192, and RGB 198 User's Manual</i>	

## Optional Accessories

Accessory	Part number
Through-desk mounting bracket kit	70-077-02
3.5 mm stereo plug	10-306-01
VGAM 3' MHRA 15-pin HD cable	26-490-01
VGAM 6' MHRA 15-pin HD cable	26-490-02
VGAM 12' MHRA 15-pin HD cable	26-490-03
Mac Adapter 15-HDM Kit with audio	70-156-01
13W3 Adapter 15-HDM Kit with audio	70-157-01
PS 100 12VDC, 2A Multi Unit Power Supply	60-357-01
Mini Architectural Adapter Plates (MAAP) (RGB 198 only)	assorted

## Cables

BNC cable	Part number
BNC-5 Mini HR 3'	26-260-15
BNC-5 Mini HR 6'	26-260-01
BNC-5 Mini HR 12'	26-260-02
BNC-5 Mini HR 25'	26-260-03
BNC-5 Mini HR 50'	26-260-04
BNC-5 Mini HR 75'	26-260-16
BNC-5 Mini HR 100'	26-260-05
MHR-5P BNC 3'	26-378-01
MHR-5P BNC 6'	26-378-02
MHR-5P BNC 12'	26-378-03
MHR-5P BNC 25'	26-378-04
MHR-5P BNC 50'	26-378-05
MHR-5P BNC 75'	26-378-06
MHR-5P BNC 100'	26-378-07

