



instruction manual

NetLinx CardFrame, Control Cards, and NetModules

NXC, NXF, and NXM Series



NetLinx Central Controllers and Cards

AMX Limited Warranty and Disclaimer

AMX Corporation warrants its products to be free of defects in material and workmanship under normal use for three (3) years from the date of purchase from AMX Corporation, with the following exceptions:

- Electroluminescent and LCD Control Panels are warranted for three (3) years, except for the display and touch overlay components that are warranted for a period of one (1) year.
- Disk drive mechanisms, pan/tilt heads, power supplies, and MX Series products are warranted for a period of one (1) year.
- AMX Lighting products are guaranteed to switch on and off any load that is properly connected to our lighting products, as long as the AMX Lighting products are under warranty. AMX Corporation does guarantee the control of dimmable loads that are properly connected to our lighting products. The dimming performance or quality cannot be guaranteed due to the random combinations of dimmers, lamps and ballasts or transformers.
- Unless otherwise specified, OEM and custom products are warranted for a period of one (1) year.
- AMX Software is warranted for a period of ninety (90) days.
- Batteries and incandescent lamps are not covered under the warranty.

This warranty extends only to products purchased directly from AMX Corporation or an Authorized AMX Dealer.

All products returned to AMX require a Return Material Authorization (RMA) number. The RMA number is obtained from the AMX RMA Department. The RMA number must be clearly marked on the outside of each box. The RMA is valid for a 30-day period. After the 30-day period the RMA will be cancelled. Any shipments received not consistent with the RMA, or after the RMA is cancelled, will be refused. AMX is not responsible for products returned without a valid RMA number.

AMX Corporation is not liable for any damages caused by its products or for the failure of its products to perform. This includes any lost profits, lost savings, incidental damages, or consequential damages. AMX Corporation is not liable for any claim made by a third party or by an AMX Dealer for a third party.

This limitation of liability applies whether damages are sought, or a claim is made, under this warranty or as a tort claim (including negligence and strict product liability), a contract claim, or any other claim. This limitation of liability cannot be waived or amended by any person. This limitation of liability will be effective even if AMX Corporation or an authorized representative of AMX Corporation has been advised of the possibility of any such damages. This limitation of liability, however, will not apply to claims for personal injury.

Some states do not allow a limitation of how long an implied warranty last. Some states do not allow the limitation or exclusion of incidental or consequential damages for consumer products. In such states, the limitation or exclusion of the Limited Warranty may not apply. This Limited Warranty gives the owner specific legal rights. The owner may also have other rights that vary from state to state. The owner is advised to consult applicable state laws for full determination of rights.

EXCEPT AS EXPRESSLY SET FORTH IN THIS WARRANTY, AMX CORPORATION MAKES NO OTHER WARRANTIES, EXPRESSED OR IMPLIED, INCLUDING ANY IMPLIED WARRANTIES OF MERCHANTABILITY OR FITNESS FOR A PARTICULAR PURPOSE. AMX CORPORATION EXPRESSLY DISCLAIMS ALL WARRANTIES NOT STATED IN THIS LIMITED WARRANTY. ANY IMPLIED WARRANTIES THAT MAY BE IMPOSED BY LAW ARE LIMITED TO THE TERMS OF THIS LIMITED WARRANTY.

Software License and Warranty Agreement

LICENSE GRANT.

AMX grants to Licensee the non-exclusive right to use the AMX Software in the manner described in this License. The AMX Software is licensed, not sold. This license does not grant Licensee the right to create derivative works of the AMX Software. The AMX Software consists of generally available programming and development software, product documentation, sample applications, tools and utilities, and miscellaneous technical information. Please refer to the README.TXT file on the compact disc or download for further information regarding the components of the AMX Software. The AMX Software is subject to restrictions on distribution described in this License Agreement. LICENSEE MAY NOT SUBLICENSE, RENT, OR LEASE THE AMX SOFTWARE. Licensee may not reverse engineer, decompile, or disassemble the AMX Software.

INTELLECTUAL PROPERTY.

The AMX Software is owned by AMX and is protected by United States copyright laws, patent laws, international treaty provisions, and/or state of Texas trade secret laws. Licensee may make copies of the AMX Software solely for backup or archival purposes. Licensee may not copy the written materials accompanying the AMX Software.

TERMINATION.

AMX RESERVES THE RIGHT, IN ITS SOLE DISCRETION, TO TERMINATE THIS LICENSE FOR ANY REASON AND UPON WRITTEN NOTICE TO LICENSEE. In the event that AMX terminates this License, the Licensee shall return or destroy all originals and copies of the AMX Software to AMX and certify in writing that all originals and copies have been returned or destroyed.

PRE-RELEASE CODE.

Portions of the AMX Software may, from time to time, as identified in the AMX Software, include PRE-RELEASE CODE and such code may not be at the level of performance, compatibility and functionality of the final code. The PRE-RELEASE CODE may not operate correctly and may be substantially modified prior to final release or certain features may not be generally released. AMX is not obligated to make or support any PRE-RELEASE CODE. ALL PRE-RELEASE CODE IS PROVIDED "AS IS" WITH NO WARRANTIES.

LIMITED WARRANTY.

AMX warrants that the AMX Software will perform substantially in accordance with the accompanying written materials for a period of ninety (90) days from the date of receipt. AMX DISCLAIMS ALL OTHER WARRANTIES, EITHER EXPRESS OR IMPLIED, INCLUDING, BUT NOT LIMITED TO IMPLIED WARRANTIES OF MERCHANTABILITY AND FITNESS FOR A PARTICULAR PURPOSE, WITH REGARD TO THE AMX SOFTWARE. THIS LIMITED WARRANTY GIVES LICENSEE SPECIFIC LEGAL RIGHTS. Any supplements or updates to the AMX SOFTWARE, including without limitation, any (if any) service packs or hot fixes provided to Licensee after the expiration of the ninety (90) day Limited Warranty period are not covered by any warranty or condition, express, implied or statutory.

LICENSEE REMEDIES.

AMX's entire liability and Licensee's exclusive remedy shall be repair or replacement of the AMX Software that does not meet AMX's Limited Warranty and which is returned to AMX. This Limited Warranty is void if failure of the AMX Software has resulted from accident, abuse, or misapplication. Any replacement AMX Software will be warranted for the remainder of the original warranty period or thirty (30) days, whichever is longer. Outside the United States, these remedies may not be available.

NO LIABILITY FOR CONSEQUENTIAL DAMAGES. IN NO EVENT SHALL AMX BE LIABLE FOR ANY DAMAGES WHATSOEVER (INCLUDING, WITHOUT LIMITATION, DAMAGES FOR LOSS OF BUSINESS PROFITS, BUSINESS INTERRUPTION, LOSS OF BUSINESS INFORMATION, OR ANY OTHER PECUNIARY LOSS) ARISING OUT OF THE USE OF OR INABILITY TO USE THIS AMX SOFTWARE, EVEN IF AMX HAS BEEN ADVISED OF THE POSSIBILITY OF SUCH DAMAGES. BECAUSE SOME STATES/COUNTRIES DO NOT ALLOW THE EXCLUSION OR LIMITATION OF LIABILITY FOR CONSEQUENTIAL OR INCIDENTAL DAMAGES, THE ABOVE LIMITATION MAY NOT APPLY TO LICENSEE.

U.S. GOVERNMENT RESTRICTED RIGHTS.

The AMX Software is provided with RESTRICTED RIGHTS. Use, duplication, or disclosure by the Government is subject to restrictions as set forth in subparagraph ©(1)(ii) of The Rights in Technical Data and Computer Software clause at DFARS 252.227-7013 or subparagraphs ©(1) and (2) of the Commercial Computer Software Restricted Rights at 48 CFR 52.227-19, as applicable.

SOFTWARE AND OTHER MATERIALS FROM AMX.COM MAY BE SUBJECT TO EXPORT CONTROL.

The United States Export Control laws prohibit the export of certain technical data and software to certain territories. No software from this Site may be downloaded or exported (i) into (or to a national or resident of) Cuba, Iraq, Libya, North Korea, Iran, Syria, or any other country to which the United States has embargoed goods; or (ii) anyone on the United States Treasury Department's list of Specially Designated Nationals or the U.S. Commerce Department's Table of Deny Orders. AMX does not authorize the downloading or exporting of any software or technical data from this site to any jurisdiction prohibited by the United States Export Laws.

This Agreement replaces and supersedes all previous AMX Software License Agreements and is governed by the laws of the State of Texas, and all disputes will be resolved in the courts in Collin County, Texas, USA. For any questions concerning this Agreement, or to contact AMX for any reason, please write: **AMX Corporation, 3000 Research Drive, Richardson, TX 75082.**

Table of Contents

NXF CardFrame and NetModules	1
NXF CardFrame	1
NXF Cardframe Specifications	2
Mounting Master/Hub Cards in an NXF CardFrame	2
Setting the CardFrame's starting address.....	3
Device:Port:System (D:P:S).....	3
NXS-NMS NetModules.....	4
NXS-NMS NetModules specifications.....	4
Mounting modules into an equipment rack	4
Installing Control Cards into an NXF CardFrame.....	5
Preparing/connecting captive wires	5
Using the ID button	5
NXC-COM2 Dual COM Port Control Card	7
Specifications	7
Pinouts and Wiring Configuration	8
NXC-COM2 Channel Assignment.....	8
NXC-COM2 Programming Information.....	9
NXC-COM2 Send_Commands	9
NXC-COM2 Send_String Escape Sequences	12
NXC-I/O10 Input/Output Control Card	15
Specifications	15
NXC-I/O10 Channel Assignments.....	16
Setting the Switch/Voltage Mode Jumpers.....	17
Setting the Voltage Clamp Jumper (+12V or Open).....	17
NXC-IRS4 4-Port IR/S Control Card	19
Specifications	19
Pinouts, Signals, and Functions	20
NXC-IRS4 Channel Assignments.....	20
Programming Information.....	20
NXC-REL10 Relay Control Card	27
Specifications	27
Pinouts and Functions.....	27
NXC-REL10 Channel Assignments.....	28
NXC-REL10 Connections/Wiring	28

NXC-VAI4 Analog Voltage Control Card 29

- Specifications 29
- Pinouts and Functions..... 30
- Channel Assignments 31
- NXC-VAI4 Output Level Assignments..... 33
- NXC-VAI4 Input Level Assignments 34
- Programming Information..... 34

NXC-VOL4 Volume Control Card 41

- Specifications 41
- Pinouts, Signals, and Functions..... 42
- NXC-VOL4 Connections/Wiring..... 43
- NXC-VOL4 Channel Assignments 43
- NXC-VOL4 Levels..... 44
 - CREATE_LEVEL 44
 - SEND_LEVEL..... 44
- Programming Information..... 45

NXF CardFrame and NetModules

NetLinx Control Cards can be installed in the NetLinx (NXF) CardFrame, the NI-4000, or in modules for stand-alone operation. The NXF CardFrame accommodates a NetLinx Master (or Hub) card, up to twelve NetLinx Control cards, and provides a back plane to distribute power and data to/from the cards. The NXF CardFrame provides terminals on the rear panel for connection to the control cards and a system power supply. A DIP switch on the rear panel sets the CardFrame's base device number.

The NetLinx Control Cards covered in this document are:

- NXC-COM2 Dual COM Port Control Card
- NXC-I/O10 Input/Output Control Card
- NXC-IRS4 4-Port IR/S Control Card
- NXC-REL10 Relay Control Card
- NXC-VAI4 Analog Voltage Control Card
- NXC-VOL4 Volume Control Card

NXF CardFrame

FIG. 1 shows the front and rear panel components of the NXF CardFrame.

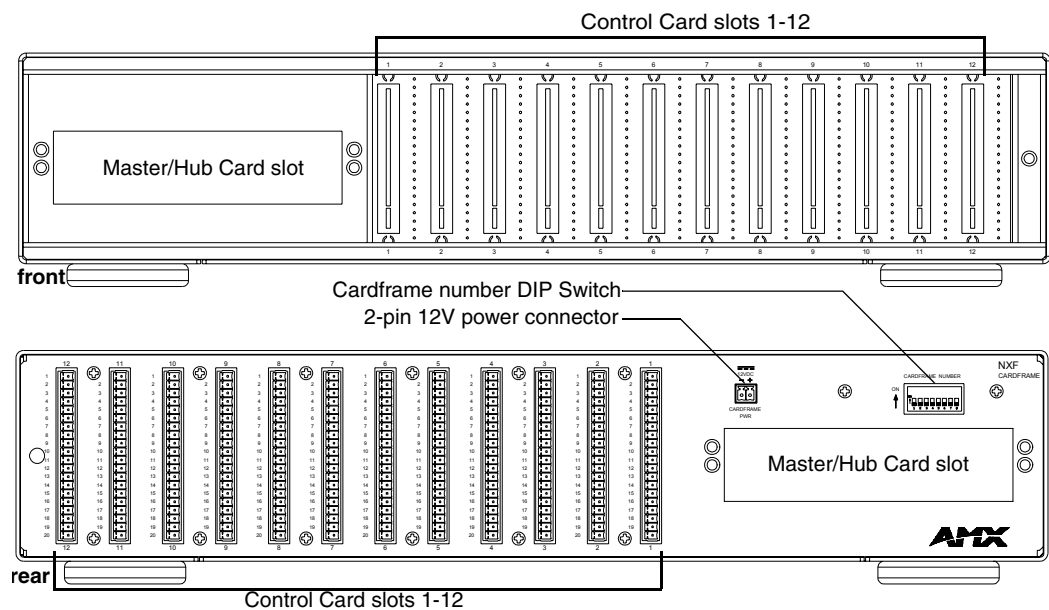

FIG. 1 NXF CardFrame

NXF Cardframe Specifications

NXF Cardframe Specifications	
Power Requirement	12 VDC; varies with installed Control Cards.
Dimensions (HWD)	3.5" x 17.0" x 9.6" (8.89 cm x 43.18 cm x 24.38 cm)
Weight	9.1 lbs (4.1 kg)
Front Panel Components:	
Master/Hub Card slot	Houses the Master or Hub Card. Refer to the <i>NetLinx Master Cards and Modules</i> or <i>NetLinx Hub Cards and Modules</i> instruction manuals for detailed information.
Control Card slots	12 card slots for the NetLinx Control Cards that control devices connected to the CardFrame.
Rack-mounting brackets	Provides for installing the CardFrame into an equipment rack.
Rear Panel Components:	
Card slots	Twelve 20-pin black (male) connectors and mating 3.5 mm captive-screw terminals supplied with Control Cards.
Control Card connectors (1-12)	20-pin black (male) connectors that connect the Control Cards and external equipment to the CardFrame.
+12 VDC PWR	2-pin green (male) connector for connecting a 12 VDC power supply. The CardFrame can be powered via the Master Card (default) or by an external power supply connected to the CardFrame's PWR connector. If a power supply is connected to the PWR connector, the CardFrame power automatically switches to the connected power supply. In that case, the Control Cards and CardFrame are independently powered. A simple rule to follow is if the CardFrame contains eight or more Control Cards, use two 12 VDC power supplies.
CardFrame Number DIP switch	Sets the starting address for the Control Cards in the CardFrame. The 8-position DIP switch address range is 1-3072.
Front faceplate	Plastic gray faceplate with translucent viewing window.
Enclosure	Metal with black matte finish.

Mounting Master/Hub Cards in an NXF CardFrame

NetLinx Master and Hub Cards can be installed in the NXF CardFrame. The card mounts in a horizontal position, through the master card slot on the rear panel of the NXF enclosure. To install a Master or Hub Card in an NXF:

1. Discharge the static electricity from your body by touching a grounded metal object.
2. Unplug all the connectors from the NXF.
3. Remove the two screws holding the front plate on the Master Card, and remove the front plate.
4. Align the edges of the card with the guide slots inside the Master Card slot on the NXF.
5. Slide the card about halfway into the slot.
6. Inside the Master Card slot on the NXF, locate the 6-pin control cable connector.
7. Plug the connector from the NXF into the 6-pin terminal on the Master Card. This connector is keyed to ensure correct orientation.
8. Once the control cable is connected, gently slide the card all the way in until you feel the rear edge of the card lightly snap into place.
9. Re-apply power and other connections as necessary.

Setting the CardFrame's starting address

The 8-position CardFrame Number DIP switch, located on the rear of the CardFrame (FIG. 1 on page 1), sets the starting address (the device number in the D:P:S specification) for the Control Cards installed in the CardFrame. The address range is 12-3060. The formula for setting the starting address is:

$$(\text{DIP switch address} \times 12) + \text{Card slot Number (1-12)} = \text{Card address}$$

For example:

- For DIP switch setting, 00010101: $(0 + 0 + 0 + 0 + 96 + 0 + 384 + 1536) + \text{SLOT \#(ex:1)} = 2017$.
 - A card in slot number 7 would be device address 2023.
1. Set the CardFrame Number DIP switch based on the information listed in the table below.

Position	1	2	3	4	5	6	7	8
Value	12	24	48	96	192	384	768	1536

2. Cycle power for approximately 5 seconds, so the system can read the new device number settings.



Factory default DIP switch value = 0 (zero) (All DIP switches are in the OFF position).

Device:Port:System (D:P:S)

A device is any hardware component that can be connected to an AXlink or ICSNet bus. Each device must be assigned a unique number to locate that device on the bus. The NetLinX programming language allows numbers in the range 0-32,767. Device 0 refers to the local Master; numbers greater than 32,767 are reserved.

NetLinX requires a Device:Port:System (D:P:S) specification. This D:P:S triplet can be expressed as a series of constants, variables separated by colons, or a DEV structure. For example:

```
STRUCTURE DEV
{
  INTEGER Number // Device number
  INTEGER Port // Port on device
  INTEGER System // System the device belongs to
}
```

The D:P:S notation is used to explicitly represent a device number, port and system. For example, 128:1:0 represents the first port on device 128 on this system. If the system and Port specifications are omitted, (e.g. 128), system 0 (indicating this system) and port 1 (the first port) is assumed.

Here's the syntax:

```
NUMBER : PORT : SYSTEM
```

where:

- NUMBER: 16-bit integer represents the device number
- PORT: 16-bit integer represents the port number (in the range 1 through the number of ports on the Controller or device)
- SYSTEM: 16-bit integer represents the system number (0 = this system)

NXS-NMS NetModules

The NXS-NMS NetModules (**FG2009-10**) accommodate one NetLinx Control Card, and connect to the NetLinx bus via ICSNet connections. The NetModules offer a simple and economical way to integrate additional functionality to control systems. FIG. 2 shows a NetModule shell and its main components.

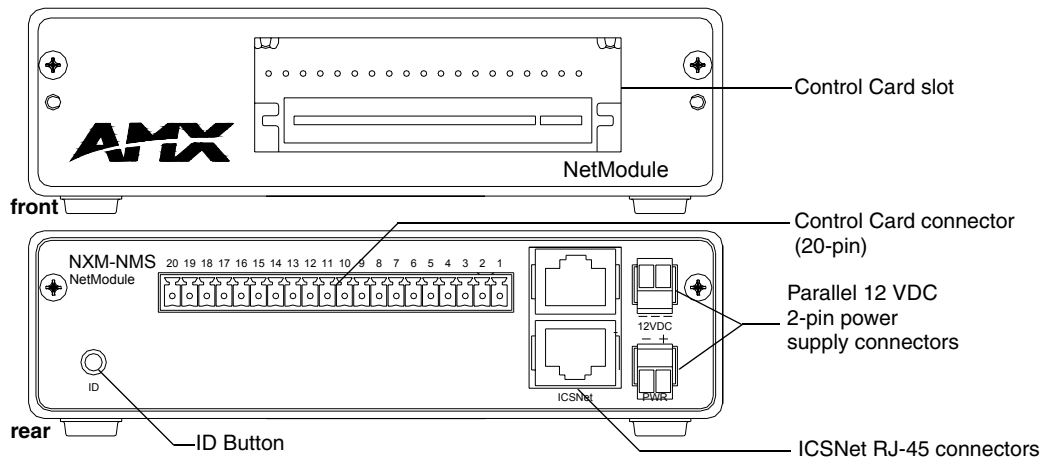

FIG. 2 NXS-NMS NetLinx NetModule shell

NXS-NMS NetModules specifications

The table below lists the NXS-NMS specifications.

NXS-NMS NetModules Specifications	
Dimensions (HWD)	1.50" x 5.55" x 9.25" (3.81 cm x 14.10 cm x 23.50 cm)
ID button	Generates an event from the NetModule to allow you to assign new Device and System numbers, using ID mode in the NetLinx Studio software program (see <i>Using the ID button</i> section on page 5 for details).
Control connector	20-pin black (male) connector that connects the NetModule to external devices. These connectors are keyed to insure proper installation.
ICSNet RJ-45 connectors	Receives power and data from a NetLinx Master/Hub ICSNet Port. An ICSNet port on a NetLinx Master or Hub supplies up to 500 mA at 12 V for module power.
12 VDC power supply connectors	Two parallel male 2-pin (green) parallel connectors for 12 VDC power.
Enclosure	Metal with black matte finish
Included Accessories	NetLinx faceplate
Optional accessories	AC-RK Accessory Rack Kit (holds up to three NetModules)

Mounting modules into an equipment rack

To install the modules in an equipment rack using the optional AC-RK kit:

1. Remove the front faceplate from the module to expose the mounting holes.
2. Mount the module on the AC-RK bracket.

3. Place the AC-RK bracket (with the module) in the equipment rack and secure the bracket to the rack.
4. Replace the front faceplate on the module, and attach the translucent plastic cover to the faceplate (if necessary).

Installing Control Cards into an NXF CardFrame

1. Remove the magnetic front faceplate/viewing window from the CardFrame.
2. Align the edge of the Control Card with a slot in the CardFrame. Slide the card into the CardFrame and press until you feel the Card seat in the backplane connector.
3. Put the magnetic faceplate back on the CardFrame. Secure with mounting screws (if necessary).

Preparing/connecting captive wires

1. Strip 0.25 inch of wire insulation off all wires.
2. Insert each wire into the appropriate opening on the connector according to the wiring diagrams and connector types described in this section.
3. Tighten the screws to secure the wires in the connector. Do not tighten the screws excessively; doing so may strip the threads and damage the connector.

Using the ID button

The ID Button on the rear panel of the NetModules (see FIG. 2) is used in conjunction with the NetLinx Studio software program to allow you to assign new Device and System numbers for the Module.

1. Using NetLinx Studio, place the system in Identity (ID) Mode. ID Mode means the entire system is put on hold while it waits for an event from any NetLinx device in the named system (for example, pushing the ID button on a Module). The device generating the first event is the identified device.
2. Press the ID Mode button to generate an event from the Module and allow you to assign new Device and System numbers in NetLinx Studio.

NXC-COM2 Dual COM Port Control Card

The NXC-COM2 Dual COM Port Control Card (FG2022) provides two RS-232, RS-422, or RS-485 control ports and LED feedback for remote sources connected to the NetLinX CardFrame, NI-4000 or NetModule. FIG. 3 shows the COM2 card.

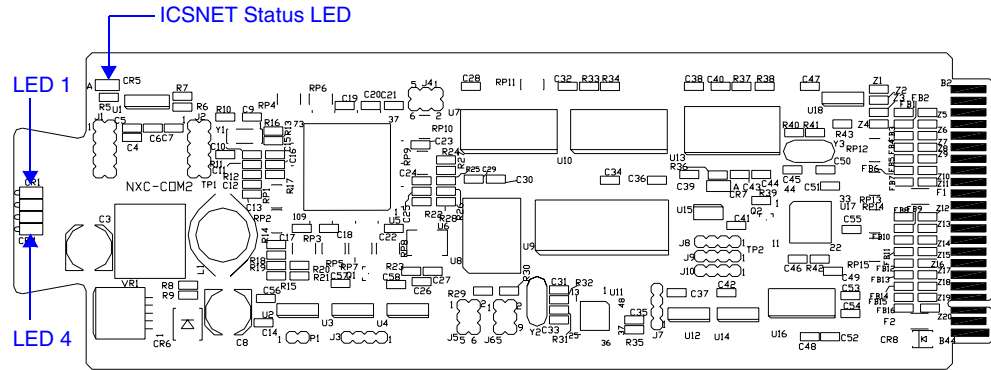

FIG. 3 NXC-COM2 Dual COM Port Control card

Specifications

NXC-COM2 Specifications	
Power Requirements:	140 mA @ 12 VDC
Operation:	Data 1-2: Two RS-232/422/485 control ports, supports XON/XOFF, CTS/RTS, 300-230,400 baud
Status LEDs (2 per channel):	<ul style="list-style-type: none"> • Red LED shows TX (transmit) data activity • Yellow LED shows RX (receive) data activity <ul style="list-style-type: none"> - LED 1: CH1 TX (red) - LED 2: CH1 RX (yellow) - LED 3: CH2 TX (red) - LED 4: CH2 RX (yellow) • Green ICSP status LED (located on the board): <ul style="list-style-type: none"> - On = card is not in communication with the Master. - Blinks (1-second intervals) during normal operation.
Connections/wiring:	Two 10-pin 3.5 mm captive-screw terminals
DEVICE_ID:	\$0107

Pinouts and Wiring Configuration

NXC-COM2 Pinouts			NXC-COM2 Wiring Configuration		
Pin	Signal	Function	RS-232	RS-422	RS-485
1	GND	Signal ground	X	X	
2	RXD1	Receive data	X		
3	TXD1	Transmit data	X		
4	CTS1	Clear to send	X		
5	RTS1	Request to send	X		
6	TX1+	Transmit data		X	X (strap to pin 8)
7	TX1-	Transmit data		X	X (strap to pin 9)
8	RX1+	Receive data		X	X (strap to pin 6)
9	RX1-	Receive data		X	X (strap to pin 7)
10	+12 VDC	Power	Optional	Optional	
11	GND	Signal ground	X	X	
12	RXD2	Receive data	X		
13	TXD2	Transmit data	X		
14	CTS2	Clear to send	X		
15	RTS2	Request to send	X		
16	TX2+	Transmit data		X	X (strap to pin 18)
17	TX2-	Transmit data		X	X (strap to pin 19)
18	RX2+	Receive data		X	X (strap to pin 16)
19	RX2-	Receive data		X	X (strap to pin 17)
20	+12 VDC	Power	Optional	Optional	

NXC-COM2 Channel Assignment

NXC-COM2 Channel Assignment	
Channel	Description
255	CTS push channel - reflects the state of the CTS input if a 'CTSPSH' command was sent to the device.

NXC-COM2 Programming Information

NXC-COM2 Send Commands

NXC-COM2 Send Commands	
Command	Description
<p>B9MOFF</p> <p>Disable 9-bit in 232/422/455 mode.</p>	<p>This command works in conjunction with the B9MON command.</p> <p>Syntax:</p> <pre>SEND_COMMAND <DEV>, "'B9MOFF'"</pre> <p>Example:</p> <pre>SEND_COMMAND SOMEDEVICE_1, "'B9MOFF'"</pre> <p>Sets the port settings on SOMEDEVICE to match the port's configuration settings.</p>
<p>B9MON</p> <p>Enable 9-bit in 232/422/455 mode.</p>	<p>This command works in conjunction with the B9MOFF command.</p> <p>Syntax:</p> <pre>SEND_COMMAND <DEV>, "'B9MON'"</pre> <p>Example:</p> <pre>SEND_COMMAND SOMEDEVICE_1, "'B9MON'"</pre> <p>Resets the SOMEDEVICE port's communication parameters to nine data bits and one stop bit.</p>
<p>CHARD</p> <p>Set the delay time between all transmitted characters to the value specified (in 100 microsecond increments).</p>	<p>Syntax:</p> <pre>SEND_COMMAND <DEV>, "'CHARD-<time>'"</pre> <p>Variable:</p> <p>time: 0 - 255. Measured in 100 microsecond increments.</p> <p>Example:</p> <pre>SEND_COMMAND RS232_1, "'CHARD10'"</pre> <p>Sets a 1-millisecond delay between all transmitted characters.</p>
<p>CHARDM</p> <p>Set the delay time between all transmitted characters to the value specified (in 1 millisecond increments).</p>	<p>Syntax:</p> <pre>SEND_COMMAND <DEV>, "'CHARDM-<time>'"</pre> <p>Variable:</p> <p>time: 0 - 255. Measured in 1 millisecond increments.</p> <p>Example:</p> <pre>SEND_COMMAND RS232_1, "'CHARDM10'"</pre> <p>Sets a 10-millisecond delay between all transmitted characters.</p>
<p>CTSPSH</p> <p>Enable Pushes, Releases, and status information to be reported via channel 255 using the CTS hardware handshake input.</p>	<p>If Clear To Send (CTS) is high, the channel is On.</p> <p>Syntax:</p> <pre>SEND_COMMAND <DEV>, "'CTSPSH'"</pre> <p>Example:</p> <pre>SEND_COMMAND RS232_1, "'CTSPSH'"</pre> <p>Sets the RS232_1 port to detect changes on the CTS input.</p>
<p>CTSPSH OFF</p> <p>Disable Pushes, Releases, and Status information to be reported via channel 255.</p>	<p>Turns CTSPSH Off. If Clear To Send (CTS) is high, the channel is on.</p> <p>Syntax:</p> <pre>SEND_COMMAND <DEV>, "'CTSPSH OFF'"</pre> <p>Example:</p> <pre>SEND_COMMAND RS232_1, "'CTSPSH OFF'"</pre> <p>Turns off CTSPSH for the specified device. Disables the RS232_1 port to detect changes on the CTS input.</p>

NXC-COM2 Send_Commands (Cont.)	
Command	Description
<p>GET BAUD Get the RS-232/422/485 port's current communication parameters.</p>	<p>Device sends the response out the Master program port.</p> <p>Syntax: SEND_COMMAND <DEV>, "'GET BAUD' "</p> <p>Example: SEND_COMMAND RS232_1, "'GET BAUD' "</p> <p>Device responds with: <port #>,<baud>,<parity>,<data>,<stop> 485 <ENABLED DISABLED></p>
<p>HSOFF Disable hardware handshaking (default).</p>	<p>Syntax: SEND_COMMAND <DEV>, "'HSOFF' "</p> <p>Example: SEND_COMMAND RS232_1, "'HSOFF' "</p> <p>Disables hardware handshaking on the RS232_1 device.</p>
<p>HSON Enable RTS (ready-to-send) and CTS (clear-to-send) hardware handshaking.</p>	<p>Syntax: SEND_COMMAND <DEV>, "'HSON' "</p> <p>Example: SEND_COMMAND RS232_1, "'HSON' "</p> <p>Enables hardware handshaking on the RS232_1 device.</p>
<p>RXCLR Clear all characters in the receive buffer waiting to be sent to the Master.</p>	<p>Syntax: SEND_COMMAND <DEV>, "'RXCLR' "</p> <p>Example: SEND_COMMAND RS232_1, "'RXCLR' "</p> <p>Clears all characters in the receive buffer waiting to be sent to the Master.</p>
<p>RXOFF Disable the transmission of incoming received characters to the Master (default).</p>	<p>Syntax: SEND_COMMAND <DEV>, "'RXOFF' "</p> <p>Example: SEND_COMMAND RS232_1, "'RXOFF' "</p> <p>Disable the transmission of incoming received characters to the Master (default).</p>
<p>RXON Start transmitting received characters to the Master (default).</p>	<p>Enables sending incoming received characters to the Master. This command is automatically sent by the Master when a 'CREATE_BUFFER' program instruction is executed.</p> <p>Syntax: SEND_COMMAND <DEV>, "'RXON' "</p> <p>Example: SEND_COMMAND RS232_1, "'RXON' "</p> <p>Stops the RS232_1 device from transmitting received characters to the Master.</p>

NXC-COM2 Send_Commands (Cont.)	
Command	Description
<p>SET BAUD</p> <p>Set the RS-232/422/485 port's communication parameters.</p>	<p>Syntax:</p> <pre>SEND_COMMAND <DEV>, "'SET BAUD <baud>, <parity>, <data>, <stop> [485 <Enable Disable>]' "</pre> <p>Variables:</p> <p>Baud: baud rates are: 230400, 115200, 76800, 57600, 38400, 19200, 9600, 4800, 2400, 1200, 600, 300, 150.</p> <p>Parity: N (none), O (odd), E (even), M (mark), S (space)</p> <p>Data: 7 or 8 data bits</p> <p>Stop: 1 or 2 stop bits</p> <p>485 Disable: Disables RS-485 mode and enables RS-232/422</p> <p>485 Enable: Enables RS-485 mode and disables RS-234/422</p> <p>Note: The only valid 9 bit combination is (baud),N,9,1.</p> <p>Example:</p> <pre>SEND_COMMAND SOMEDEVICE_1, "'SET BAUD 115200,N,8,1, 485 ENABLE' "</pre> <p>Sets the SOMEDEVICE port's communication parameters to 115,200 baud, no parity, 8 data bits, 1 stop bit, and enables RS-485 mode.</p>
<p>TSET BAUD</p> <p>Temporarily set the RS-232/422/485 port's communication parameters for a device.</p>	<p>TSET BAUD works the same as SET BAUD, except that the changes are not permanent, and the previous values will be restored if the power is cycled on the device.</p> <p>Syntax:</p> <pre>SEND_COMMAND <DEV>, "'TSET BAUD <baud>, <parity>, <data>, <stop> [485 <Enable Disable>]' "</pre> <p>Variables:</p> <p>Baud: baud rates are: 230400, 115200, 76800, 57600, 38400, 19200, 9600, 4800, 2400, 1200, 600, 300, 150.</p> <p>Parity: N (none), O (odd), E (even), M (mark), S (space)</p> <p>Data: 7 or 8 data bits</p> <p>Stop: 1 or 2 stop bits</p> <p>485 Disable: Disables RS-485 mode and enables RS-232/422</p> <p>485 Enable: Enables RS-485 mode and disables RS-234/422</p> <p>Note: The only valid 9 bit combination is (baud),N,9,1.</p> <p>Example:</p> <pre>SEND_COMMAND RS232_1, "'TSET BAUD 115200,N,8,1 485 ENABLE' "</pre> <p>Sets the RS232_1 port's communication parameters to 115,200 baud, no parity, 8 data bits, 1 stop bit, and enables RS-485 mode.</p>
<p>TXCLR</p> <p>Stop and clear all characters waiting in the transmit out buffer and stops transmission.</p>	<p>Syntax:</p> <pre>SEND_COMMAND <DEV>, "'TXCLR' "</pre> <p>Example:</p> <pre>SEND_COMMAND RS232_1, "'TXCLR' "</pre> <p>Clears and stops all characters waiting in the RS232_1 device's transmit buffer.</p>

NXC-COM2 Send_Commands (Cont.)	
Command	Description
XOFF Disable software handshaking (default).	Syntax: <code>SEND_COMMAND <DEV>, "'XOFF'"</code> Example: <code>SEND_COMMAND RS232_1, "'XOFF'"</code> Disables software handshaking on the RS232_1 device.
XON Enable software handshaking.	Syntax: <code>SEND_COMMAND <DEV>, "'XON'"</code> Example: <code>SEND_COMMAND RS232_1, "'XON'"</code> Enables software handshaking on the RS232_1 device.

NXC-COM2 Send_String Escape Sequences

NXC-COM2 Send_String Escape Sequences	
Command	Description
27,17,<time> Send a break character for a specified duration to a specific device.	Syntax: <code>SEND_STRING <DEV>, "27,17,<time>"</code> Variable: time = 1 - 255. Measured in 100 microsecond increments. Example: <code>SEND_STRING RS232_1, "27,17,10"</code> Sends a break character of 1 millisecond to the RS232_1 device.
27,18,0 Clear the ninth data bit by setting it to 0 on all character transmissions.	Used in conjunction with the 'B9MON' command. Syntax: <code>SEND_STRING <DEV>, "27,18,0"</code> Example: <code>SEND_STRING RS232_1, "27,18,0"</code> Sets the RS232_1 device's ninth data bit to 0 on all character transmissions.
27,18,1 Set the ninth data bit to 1 for all subsequent characters to be transmitted.	Used in conjunction with the 'B9MON' command. Syntax: <code>SEND_STRING <DEV>, "27,18,1"</code> Example: <code>SEND_STRING RS232_1, "27,18,1"</code> Sets the RS232_1 device's ninth data bit to 1 on all character transmissions.
27,19,<time> Insert a time delay before transmitting the next character.	Syntax: <code>SEND_STRING <DEV>, "27,19,<time>"</code> Variable: time = 1 - 255. Measured in 1 millisecond increments. Example: <code>SEND_STRING RS232_1, "27,19,10"</code> Inserts a 10 millisecond delay before transmitting characters to the RS232_1 device.

NXC-COM2 Send_String Escape Sequences (Cont.)	
Command	Description
27,20,0 Set the RTS hardware handshake's output to high (> 3V).	Syntax: <code>SEND_STRING <DEV>, "27,20,0"</code> Example: <code>SEND_STRING RS232_1, "27,20,0"</code> Sets the RTS hardware handshake's output to high on the RS232_1 device.
27,20,1 Set the RTS hardware handshake's output to low/inactive (< 3V).	Syntax: <code>SEND_STRING <DEV>, "27,20,1"</code> Example: <code>SEND_STRING RS232_1, "27,20,1"</code> Sets the RTS hardware handshake's output to low on the RS232_1 device.

NXC-I/O10 Input/Output Control Card

The NXC-I/O10 Input/Output Control Card (**FG2021**) provides 10 Input/Output channels and LED feedback. It acts as a logic-level input and responds to switch closures or voltage level (high/ low) changes. The Switch (SW) and Voltage (VO) modes are set with on-board jumpers. FIG. 4 shows the I/O10 card.



The I/Os on this card are not dry closure; they are electronic switches that float at 5V when Off. Therefore, they should not be expected to work in situations that require true dry contact (or dry closure).

The I/Os do work with AMX PC1, PC2, UPC20 and UPC20+.

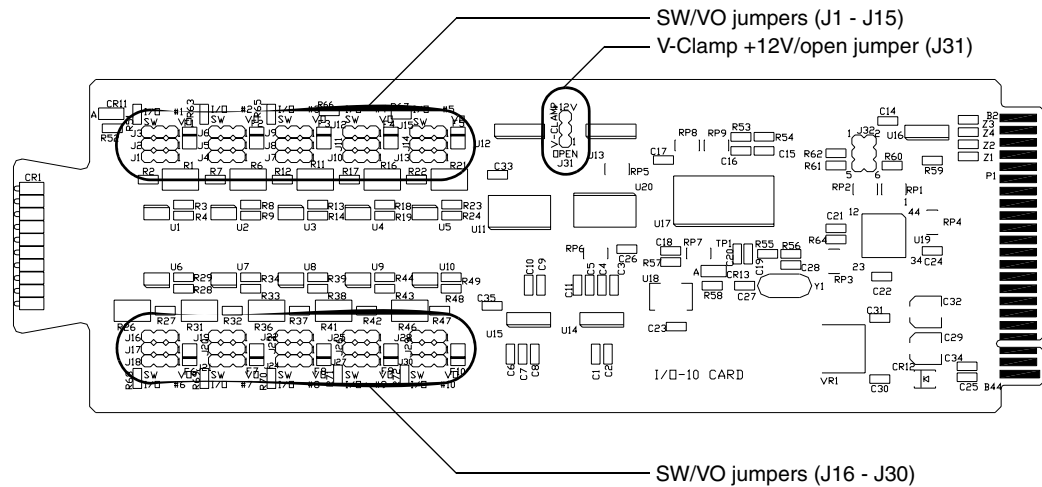

FIG. 4 NXC-I/O10 Control card

Specifications

NXC-I/O10 Specifications	
Power Requirements	180 mA @ 12 VDC
Operation	I/O 1-10: ten Input/Output channels
Status LEDs (1 per channel)	Yellow LEDs light to show ON status activity
Modes:	
Switch	Senses switch or relay contact closures or provides a logic-level output.
Voltage	Senses high- and low-voltage states.
Voltage clamp settings:	
12 V mode (default)	Clamps any voltage connected to I/O ports 1-10 to 12 V.
VO mode	Use for connections that will draw more than 12 V.
Connections/wiring	Two 10-pin 3.5 mm captive-screw terminals

Pinouts, Signals, and I/O Mode Functions

NXC-I/O10 Pinouts, Signals, and I/O Mode Functions			
Pin	Signal	SW mode Functions	VO mode functions
1	Common	Signal ground	Common #1
2	I/O #1	Input #1	Input #1
3	Common	Signal ground	Common #2
4	I/O #2	Input #2	Input #2
5	Common	Signal ground	Common #3
6	I/O #3	Input #3	Input #3
7	Common	Signal ground	Common #4
8	I/O #4	Input #4	Input #4
9	Common	Signal ground	Common #5
10	I/O #5	Input #5	Input #5
11	Common	Signal ground	Common #6
12	I/O #6	Input #6	Input #6
13	Common	Signal ground	Common #7
14	I/O #7	Input #7	Input #7
15	Common	Signal ground	Common #8
16	I/O #8	Input #8	Input #8
17	Common	Signal ground	Common #9
18	I/O #9	Input #9	Input #9
19	Common	Signal ground	Common #10
20	I/O #10	Input #10	Input #10

NXC-I/O10 Channel Assignments

NXC-I/O Channel Assignment	
Channel	Description
1-10	Represent I/O channels 1-10

Setting the Switch/Voltage Mode Jumpers

The NXC-I/O10 responds to switch closures or voltage-level (high/low) changes. Compatible I/O devices include the Power Control Sensor (PCS), tape transports and limit switches. The inputs are set for SW mode (closure) or VO mode as described below.



SW (switch) Mode setting (default)
(Jumper pins 2 and 3)

Senses switch or relay contact closures or provides a logic-level output. The 3-pin jumpers for each input should be set to SW before wiring inputs to the Card. An "On" condition is triggered by contact closures or a logic low of 0 to 1.5 VDC. An "Off" condition is triggered by a logic high of 2.5 to 5 VDC; set the associated I/O to switch mode. When used for an output, each I/O port acts as a switch to ground (GND), and is rated at 200 mA @ 12 VDC.



VO (voltage) Mode setting
(Jumper pins 1 and 2)

Senses high- and low-voltage states commonly from AC or DC signals. This mode provides opto-isolation. The 3-pin jumpers for each input should be set to VO (voltage mode) before wiring inputs to the Card. An "On" condition is triggered by DC levels from 2.5 to 28 VDC (+ or -), or AC levels from 2.5 to 24 VAC. An "Off" condition is triggered by DC levels from 0 to 1.5 VDC (+ or -) or AC levels from 0 to 1.5 VAC.



In switch mode, the A terminals are connected to the NetLinx Controller's ground. Sources that require isolation from the Controller's ground should use voltage mode, and provide switched DC power for sensing as required.

Setting the Voltage Clamp Jumper (+12V or Open)

Set the V- Clamp jumper (J31) to +12 V (default) to clamp any voltage connected to I/O ports 1-10 to 12 V. Set to Open for connections that will draw more than 12 V. Remember, the +12 V and OPEN settings are only enabled when the I/O ports are set to SW mode. The V-Clamp jumper settings are described below.

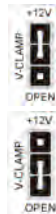

+12 V mode setting (default) Use the default setting for all loads that require less than 12 V.

Open mode setting When this jumper is set to Open, and an I/O port is used as an output, the I/O port is rated at 85 mA @ 28 VDC.

When this jumper is Open, it is the technician's responsibility to clamp the external source relay anytime the voltage exceeds 12 V. The source relay should always be clamped if the voltage exceeds 12 V. Contact the relay manufacturer to determine the size of the diode in the source relay.

NXC-IRS4 4-Port IR/S Control Card

The NXC-IRS4 4-Port IR/S Control Card (FG2023) provides four IR/Serial input control ports with LED status feedback. Each port in the NXC-IRS4 stores programmed commands for IR- or serial-controlled devices. FIG. 5 shows the IRS4 card.

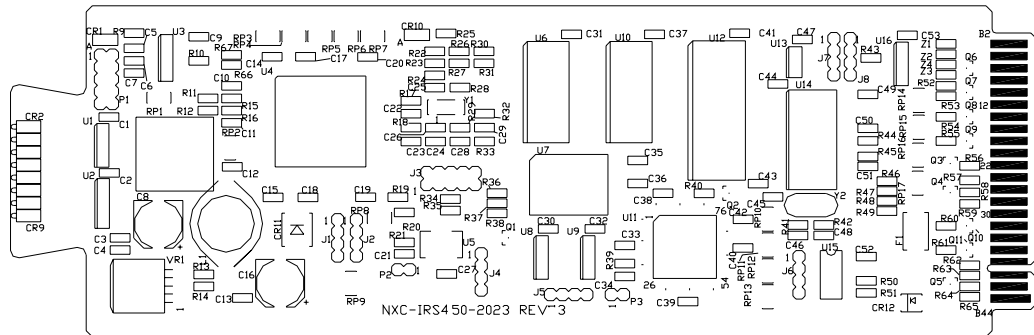

FIG. 5 NXC-IRS4 4-Port IR/Serial Control card

Specifications

NXC-IRS4 Specifications	
Power Requirements	110 mA @ 12 VDC
Power	+12 VDC power for sensors
Operation:	
IR 1-4	4 IR/Serial control ports
Input 1-4	4 input ports for closure or 0-5 VDC sensing, 200 mA
Memory	32K of IR memory shared between four ports.
IR Frequency range	Support of high-frequency carriers up to 1.14 MHz.
Status LEDs: (2 LEDs per channel) LEDs light to indicate ON status	Red LED shows IR transmission activity/Yellow LED shows input status activity: LED 1: Channel 1 Input (yellow) LED 2: Channel 1 IR Out (red) LED 3: Channel 2 Input (yellow) LED 4: Channel 2 IR Out (red) LED 5: Channel 3 Input (yellow) LED 6: Channel 3 IR Out (red) LED 7: Channel 4 Input (yellow) LED 8: Channel 4 IR Out (red)
Connections/wiring	<ul style="list-style-type: none"> Two 2-pin 3.5 mm captive-screw terminals Two CC-NIRC IR Emitters

Pinouts, Signals, and Functions

NXC-IRS4 Pinouts, Signals, and Functions					
Pin	Signal	Function	Pin	Signal	Function
1	GND	Signal ground	10	Input #1	Logic input
2	Output #1	IR data	11	Input #2	Logic input
3	GND	Signal ground	12	Input #3	Logic input
4	Output #2	IR data	13	Input #4	Logic input
5	GND	Signal ground	14	Power	+12 VDC
6	Output #3	IR data	15	-----	no connection
7	GND	Signal ground	16	-----	no connection
8	Output #4	IR data	17	-----	no connection
9	GND	Signal ground	18	-----	no connection
			19	-----	no connection
			20	-----	no connection

NXC-IRS4 Channel Assignments

The NXC-IRS4 channel settings listed in the following table set the IR output channels. The NXC-IRS4 can process up to two IR or serial device channel setting commands simultaneously.

NXC-IRS4 Channel Assignments	
Channel	Description
1-255	Generate the IR or serial command assigned to that channel.
1-199	Provide intelligent feedback; if a channel with no IR command turned On, the card will turn that channel Off.
Ports 1-4	Generate PUSH and RELEASE statements corresponding to the state of inputs 1 - 4. A contact closure to GND is reported as a PUSH. <ul style="list-style-type: none"> • The PUSH and RELEASE channel is 255. • Channel reporting status is 255. • Channel 255 changes are disabled after receipt of the 'PON' command.

Programming Information

The following NetLinx Send_Commands control the NXC-IRS4 Control Card.

NXC-IRS4 Send_Commands	
Command	Description
CAROFF Disable the IR carrier signal until a 'CARON' command is received.	Syntax: <code>SEND_COMMAND <DEV>, "'CAROFF' "</code> Example: <code>SEND_COMMAND IR_1, "'CAROFF' "</code> Stops transmitting IR carrier signals to the IR_1 port.
CARON Enable the IR carrier signals (default).	Syntax: <code>SEND_COMMAND <DEV>, "'CARON' "</code> Example: <code>SEND_COMMAND IR_1, "'CARON' "</code> Starts transmitting IR carrier signals to the IR_1 port.

NXC-IRS4 Send_Commands (Cont.)	
Command	Description
<p>CH Send IR pulses for the selected a channel.</p>	<p>All channels below 100 are transmitted as two digits. If the IR code for ENTER (function #21) is loaded, an Enter will follow the number. If the channel is greater than or equal to (>=) 100, then IR function 127 or 20 (whichever exists) is generated for the one hundred digit. Uses 'CTON' and 'CTOF' times for pulse times.</p> <p>Syntax: SEND_COMMAND <DEV>, "'CH', <Number>"</p> <p>Variable: channel number = 0 - 199.</p> <p>Example: SEND_COMMAND IR_1, "'CH', 18"</p> <p>The NXC-IRS4 performs the following:</p> <ul style="list-style-type: none"> • Transmits IR signals for 1 (IR code 11). The transmit time is set with the CTON command. • Waits until the time set with the CTOF command elapses. • Transmits IR signals for 8 (IR code 18). • Waits for the time set with the CTOF command elapses. If the IR code for Enter (IR code 21) is programmed, the IRS4 performs the following steps. • Transmits IR signals for Enter (IR code 21). <p>Waits for the time set with the CTOF command elapses.</p>
<p>CP Halt and Clear all active or buffered IR commands, and then send a single IR pulse.</p>	<p>You can set the Pulse and Wait times with the 'CTON' and 'CTOF' commands.</p> <p>Syntax: SEND_COMMAND <DEV>, "'CP', <code>"</p> <p>Variable: code = IR port's channel value 0 - 252 (253 - 255 reserved).</p> <p>Example: SEND_COMMAND IR_1, "'CP', 2"</p> <p>Clears the active/buffered commands and pulses IR_1 port's channel 2.</p>
<p>CTOF Set the duration of the Off time (no signal) between IR pulses for channel and IR function transmissions.</p>	<p>Off time settings are stored in non-volatile memory. This command sets the delay time between pulses generated by the 'CH' or 'XCH' send commands in tenths of seconds.</p> <p>Syntax: SEND_COMMAND <DEV>, "'CTOF', <time>"</p> <p>Variable: time = 0 - 255. Given in 1/10ths of a second. Default is 5 (0.5 seconds).</p> <p>Example: SEND_COMMAND IR_1, "'CTOF', 10"</p> <p>Sets the Off time between each IR pulse to 1 second.</p>
<p>CTON Set the total time of IR pulses transmitted and is stored in non-volatile memory.</p>	<p>This command sets the pulse length for each pulse generated by the 'CH' or 'XCH' send commands in tenths of seconds.</p> <p>Syntax: SEND_COMMAND <DEV>, "'CTON', <time>"</p> <p>Variable: time = 0 - 255. Given in 1/10ths of a second. Default is 5 (0.5 seconds).</p> <p>Example: SEND_COMMAND IR_1, "'CTON', 20"</p> <p>Sets the IR pulse duration to 2 seconds.</p>

NXC-IRS4 Send_Commands (Cont.)	
Command	Description
<p>GET MODE</p> <p>Poll the IR/Serial port's configuration parameters and report the active mode settings to the device requesting the information.</p>	<p>The port responds with: <port #> <mode>,<carrier>,<io link channel>.</p> <p>Syntax:</p> <pre>SEND_COMMAND <DEV>, "'GET MODE' "</pre> <p>Example:</p> <pre>SEND_COMMAND IR_1, "'GET MODE'"</pre> <p>The system could respond with:</p> <pre>PORT 4 IR, CARRIER, IO LINK 0</pre>
<p>IROFF</p> <p>Halt and Clear all active or buffered IR commands being output on the designated port.</p>	<p>Syntax:</p> <pre>SEND_COMMAND <DEV>, "'IROFF' "</pre> <p>Example:</p> <pre>SEND_COMMAND IR_1, "'IROFF'"</pre> <p>Immediately halts and clears all IR output signals on the IR_1 port.</p>
<p>POD</p> <p>Disable previously active 'PON' (power on) or 'POF' (power off) command settings.</p>	<p>Channel 255 changes are enabled. This command is used in conjunction with the I/O Link command.</p> <p>Syntax:</p> <pre>SEND_COMMAND <DEV>, "'POD' "</pre> <p>Example:</p> <pre>SEND_COMMAND IR_1, "'POD'"</pre> <p>Disables the 'PON' and 'POF' command settings on the IR_1 device.</p>
<p>POF</p> <p>Turn OFF a device connected to an IR port based on the status of the corresponding I/O Link input.</p>	<p>If at any time the IR sensor input reads that the device is ON (such as if someone turned it on manually at the front panel), IR function 28 (if available) or IR function 9 is automatically generated in an attempt to turn the device back OFF. If three attempts fail, the IR port will continue executing commands in the buffer.</p> <p>If there are no commands in the buffer, the IR port will continue executing commands in the buffer and trying to turn the device OFF until a 'PON' or 'POD' command is received. If the IR port fails to turn the device OFF, a PUSH and RELEASE is made on channel 254 to indicate a power failure error. You can only use the 'PON' and 'POF' commands when an IR device has a linked I/O channel. Channel 255 changes are disabled after receipt of this command.</p> <p>You can only use the PON and POF commands when an IR device has a linked I/O channel.</p> <p>Syntax:</p> <pre>SEND_COMMAND <DEV>, "'POF' "</pre> <p>Example:</p> <pre>SEND_COMMAND IR_1, "'POF' "</pre> <p>Sends power down IR commands 28 (if present) or 9 to the IR_1 device.</p>

NXC-IRS4 Send_Commands (Cont.)	
Command	Description
<p>PON Turn ON a device connected to an IR port based on the status of the corresponding I/O Link input.</p>	<p>If at any time the IR sensor input reads that the device is OFF (such as if one turned it off manually at the front panel), IR function 27 (if available) or IR function 9 is automatically generated in an attempt to turn the device back ON. If three attempts fail, the IR port will continue executing commands in the buffer and trying to turn the device On.</p> <p>If there are no commands in the buffer, the IR port will continue trying to turn the device ON until a 'POF' or 'POD' command is received. If the IR port fails to turn the device ON, a PUSH and RELEASE is made on channel 254 to indicate a power failure error.</p> <p>You can only use the 'PON' and 'POF' commands when an IR device has a linked I/O channel. Channel 255 changes are disabled after receipt of this command.</p> <p>Syntax: SEND_COMMAND <DEV>, "'PON' "</p> <p>Example: SEND_COMMAND IR_1, "'PON' "</p> <p>Sends power up IR commands 27 or 9 to the IR_1 port.</p>
<p>PTOF Set the time duration between power pulses in .10-second increments.</p>	<p>This time increment is stored in permanent memory. This command also sets the delay between pulses generated by the 'PON' or 'POF' send commands in tenths of seconds. It also sets the delay required after a power ON command before a new IR function can be generated. This gives the device time to power up and get ready for future IR commands. It also sets the delay required after a power ON command before a new IR function can be generated. This gives the device time to power up and get ready for future IR commands.</p> <p>Syntax: SEND_COMMAND <DEV>, "'PTOF', <time> "</p> <p>Variable: time = 0 - 255. Given in 1/10ths of a second. Default is 15 (1.5 seconds).</p> <p>Example: SEND_COMMAND IR_1, "'PTOF', 15 "</p> <p>Sets the time between power pulses to 1.5 seconds for the IR_1 device.</p>
<p>PTON Set the time duration between power pulses in .10-second increments.</p>	<p>This time increment is stored in permanent memory. This command also sets the pulse length for each pulse generated by the 'PON' or 'POF' send commands in tenths of seconds.</p> <p>Syntax: SEND_COMMAND <DEV>, "'PTON', <time> "</p> <p>Variable: time = 0 - 255. Given in 1/10ths of a second. Default is 5 (0.5 seconds).</p> <p>Example: SEND_COMMAND IR_1, "'PTON', 15 "</p> <p>Sets the duration of the power pulse to 1.5 seconds for the IR_1 device.</p>

NXC-IRS4 Send_Commands (Cont.)	
Command	Description
<p>SET INPUT LINK</p> <p>Sets an IR device to link to an input channel for use with 'PON' and 'POF' commands. This input channel is used for power sensing (via the PCS). A channel of zero disables the link.</p> <p>Syntax:</p> <pre>SEND_COMMAND <DEV>, "'SET INPUT LINK <channel>' "</pre> <p>Variable:</p> <p>channel = 1 - 4. Setting the channel to 0 disables the link.</p> <p>Example:</p> <pre>SEND_COMMAND IR_1, "'SET INPUT LINK 1' "</pre> <p>Sets the IR_1 port link to I/O channel 1. The IR port uses the specified input as power status for processing PON and POF commands.</p>	<p>Sets an IR device to link to an input channel for use with 'PON', and 'POF' commands. This input channel is used for power sensing (via the PCS). A channel of zero disables the link.</p> <p>Syntax:</p> <pre>SEND_COMMAND <DEV>, "'SET INPUT LINK <channel>' "</pre> <p>Variable:</p> <p>channel = 1 - 4. Setting the channel to 0 disables the link.</p> <p>Example:</p> <pre>SEND_COMMAND IR_1, "'SET INPUT LINK 1' "</pre> <p>Sets the IR_1 port link to I/O channel 1. The IR port uses the specified input as power status for processing PON and POF commands.</p>
<p>SET IO LINK</p> <p>Link an IR or Serial port to a selected I/O channel for use with the 'DE', 'POD', 'PON', and 'POF' commands.</p>	<p>The I/O status is automatically reported on channel 255 on the IR port. The I/O channel is used for power sensing (via a PCS or VSS). A channel of zero disables the I/O link.</p> <p>Syntax:</p> <pre>SEND_COMMAND <DEV>, "'SET IO LINK <I/O number>' "</pre> <p>Variable:</p> <p>I/O number = 1 - 4. Setting the I/O channel to 0 disables the I/O link.</p> <p>Example:</p> <pre>SEND_COMMAND IR_1, "'SET INPUT LINK 1' "</pre> <p>Sets the IR_1 port link to I/O channel 1. The IR port uses the specified input as power status for processing PON and POF commands.</p> <p>NOTE: This command is included for older programs only. The Input port is not an I/O. No output functions are available. 'SET IO LINK' applies the same configuration as the 'SET INPUT LINK' command.</p>
<p>SET MODE</p> <p>Set the IR/Serial ports for IR or Serial-controlled devices connected to a CardFrame or NetModule.</p>	<p>Sets an IR port to either IR or Serial mode.</p> <p>Syntax:</p> <pre>SEND_COMMAND <DEV>, 'SET MODE <mode>' "</pre> <p>Variable:</p> <p>mode = IR or SERIAL.</p> <p>Example:</p> <pre>SEND_COMMAND IR_1, "'SET MODE IR' "</pre> <p>Sets the IR_1 port to IR mode for IR control.</p>
<p>SP</p> <p>Generate a single IR pulse.</p>	<p>You can use the 'CTON' to set pulse lengths and the 'CTOF' for time off between pulses.</p> <p>Syntax:</p> <pre>SEND_COMMAND <DEV>, "'SP', <code>"</pre> <p>Variable:</p> <p>code = IR code value 1 - 252 (253-255 reserved).</p> <p>Example:</p> <pre>SEND_COMMAND IR_1, "'SP', 25"</pre> <p>Pulses IR code 25 on IR_1 device.</p>
<p>XCH</p> <p>Transmit the selected channel IR codes in the format/pattern set by the 'XCHM' send command.</p>	<p>Syntax:</p> <pre>SEND_COMMAND <DEV>, "'XCH <channel>' "</pre> <p>Variable:</p> <p>channel = 0 - 999.</p> <p>Example:</p> <p>For detailed usage examples, refer to the 'XCHM' command.</p>

NXC-IRS4 Send_Commands (Cont.)	
Command	Description
<p>XCHM</p> <p>Changes the IR output pattern for the 'XCH' send command.</p>	<p>Syntax:</p> <pre>SEND_COMMAND <DEV>,"'XCHM <extended channel mode>' "</pre> <p>Variable:</p> <p>extended channel mode = 0 - 4.</p> <p>Example:</p> <pre>SEND_COMMAND IR_1,"'XCHM 3' "</pre> <p>Sets the IR_1 device's extended channel command to mode 3.</p> <p>Mode 0 Example (default): [x][x]<x><enter></p> <pre>SEND_COMMAND IR_1,"'XCH 3' "</pre> <p>Transmits the IR code as 3-enter.</p> <pre>SEND_COMMAND IR_1,"'XCH 34' "</pre> <p>Transmits the IR code as 3-4-enter.</p> <pre>SEND_COMMAND IR_1,"'XCH 343' "</pre> <p>Transmits the IR code as 3-4-3-enter.</p> <p>Mode 1 Example: <x> <x> <x> <enter></p> <pre>SEND_COMMAND IR_1,"'XCH 3' "</pre> <p>Transmits the IR code as 0-0-3-enter.</p> <pre>SEND_COMMAND IR_1,"'XCH 34' "</pre> <p>Transmits the IR code as 0-3-4-enter.</p> <pre>SEND_COMMAND IR_1,"'XCH 343' "</pre> <p>Transmits the IR code as 3-4-3-enter.</p> <p>Mode 2 Example: <x> <x> <x></p> <pre>SEND_COMMAND IR_1,"'XCH 3' "</pre> <p>Transmits the IR code as 0-0-3.</p> <pre>SEND_COMMAND IR_1,"'XCH 34' "</pre> <p>Transmits the IR code as 0-3-4.</p> <pre>SEND_COMMAND IR_1,"'XCH 343' "</pre> <p>Transmits the IR code as 3-4-3.</p> <p>Mode 3 Example: [[100][100]...] <x> <x></p> <pre>SEND_COMMAND IR_1,"'XCH 3' "</pre> <p>Transmits the IR code as 0-3.</p> <pre>SEND_COMMAND IR_1,"'XCH 34' "</pre> <p>Transmits the IR code as 3-4.</p> <pre>SEND_COMMAND IR_1,"'XCH 343' "</pre> <p>Transmits the IR code as 100-100-100-4-3.</p> <p>Mode 4:</p> <p>Mode 4 sends the same sequences as the 'CH' command. Only use Mode 4 with channels 0 - 199.</p>

NXC-REL10 Relay Control Card

The NXC-REL10 Relay Control Card (FG2020) provides ten relays that support devices that employ simple momentary or latching contact-closure control, with LED feedback. FIG. 6 shows the REL-10 card:

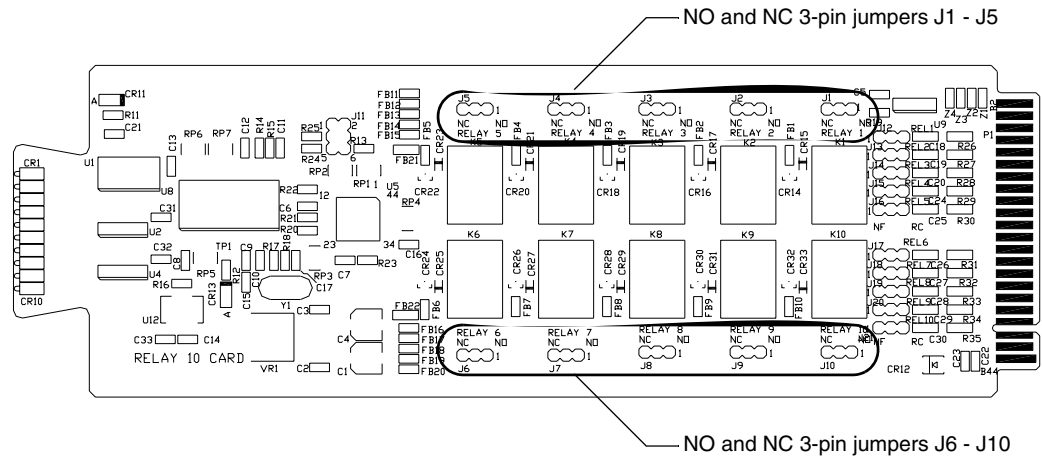

FIG. 6 NXC-REL10 Relay 10 Control card

Specifications

NXC-REL10 Specifications	
Power Requirements	260 mA @ 12 VDC
Operation	Relay 1-10: ten relays, 1A @ , 24 VAC / 28 VDC
LEDs	Ten red LEDs light to show ON status activity for each relay
Wiring:	<ul style="list-style-type: none"> • Two 10-pin 3.5 mm captive-screw terminals • Commoning strip (metal)

Pinouts and Functions

NXC-REL10 Pinouts and Functions			
Pin	Function	Pin	Function
1	Relay 1A	11	Relay 6A
2	Relay 1B	12	Relay 6B
3	Relay 2A	13	Relay 7A
4	Relay 2B	14	Relay 7B
5	Relay 3A	15	Relay 8A
6	Relay 3B	16	Relay 8B
7	Relay 4A	17	Relay 9A
8	Relay 4B	18	Relay 9B
9	Relay 5A	19	Relay 10A
10	Relay 5B	20	Relay 10B

NXC-REL10 Channel Assignments

Channels 1-10 represent relays 1-10.

NXC-REL10 Connections/Wiring

The NXC-REL10 Control Card has 10 relays that are independently controlled and electrically isolated. The relay contacts are rated for a maximum of 1 A @ 0-24 VAC or 0-28 VDC (resistive). Jumpers located on the Card allow you to select Normally Open (NO) or Normally Closed (NC) contact settings:



- Normally open (NO) mode setting on jumper pins 1 and 2 (default).



- Normally closed (NC) mode setting on jumper pins 2 and 3.

NXC-VAI4 Analog Voltage Control Card

The NXC-VAI4 Analog Voltage Control Card (**FG2025**) provides four independent analog-to-digital inputs and four independent digital-to-analog outputs, which are controllable over the ICSP network. Each port can be configured for a variety of DC input and output signals. The NXC-VAI4 incorporates the functionality of the AXC-VAI2 and AXC-VRG AXlink cards. FIG. 7 shows the VAI4 card:

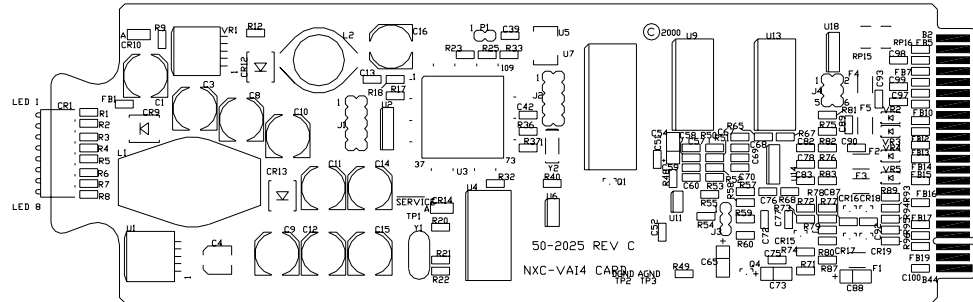

FIG. 7 NXC-VAI4 Analog Voltage Control card

Specifications

NXC-VAI4 Specifications	
Power Requirements	330 mA @ 12 VDC
Inputs	Four high-impedance analog DC inputs.
Outputs	Four analog DC outputs (user-configurable).
D/A, A/D conversion	A/D and D/A converters for analog sampling and control. 8 or 10-bit; user-selectable via the ADMODE Send_Command (see the <i>Programming Information</i> section on page 34 for details)
Available input voltages	0 V to +12 V
Available output voltages: -12 V to +12 V	The output voltage may be software-configured for any min. and max. levels between -12 and +12 VDC. <ul style="list-style-type: none"> • Maximum output current = 60 mA. • Over-voltage protection to +28 VDC.
External reference	A user supplied external reference voltage can be used to set the maximum voltage range for the D/A outputs. The full analog output range is scaled to fit the maximum range set by the external reference. Output voltage may be set to any level between 0-12 VDC, referenced to the external reference voltage input and NXC-VAI4 power supply GND.
External reference input: (EREF - one for each output)	<ul style="list-style-type: none"> • Maximum external reference input voltage = +12 VDC. • Over-voltage protection to +28 VDC.
Internal reference output: (IREF)	<ul style="list-style-type: none"> • +5 V reference output, maximum current = 60 mA. • This output is intended to drive a ground-referenced load.

NXC-VAI4 Specifications (Cont.)	
<p>I/O Status LEDs 1-8: (two LEDs per channel) LEDs light to indicate ON status.</p>	<ul style="list-style-type: none"> • 4 yellow LED's (one per channel) light to indicate input signal changes reported to the Master. • 4 red LED's (one per channel) light to indicate output signal changes. <p>LED 1: Output #1 (red) LED 2: Input #1 (yellow) LED 3: Output #2 (red) LED 4: Input #2 (yellow) LED 5: Output #3 (red) LED 6: Input #3 (yellow) LED 7: Output #4 (red) LED 8: Input #4 (yellow)</p> <p>The card is shipped in "factory-default" mode (i.e. the levels have not been configured for each channel). The Output (red) LEDs blink in sequence to indicate that the power-up or limit levels have not been set. The Output LED for each channel will continue to blink until the channel has been calibrated.</p>
<p>Wiring</p>	<p>Captive-wire connectors.</p>

Pinouts and Functions

NXC-VAI4 Pinouts, Signals, and Functions			
Pin	Function	Pin	Function
1	Output #1 (GND)	9	Input #1 (GND)
2	Output #1	10	Input #1
3	Output #2 (GND)	11	Input #2 (GND)
4	Output #2	12	Input #2
5	Output #3 (GND)	13	Input #3 (GND)
6	Output #3	14	Input #3
7	Output #4 (GND)	15	Input #4 (GND)
8	Output #4	16	Input #4
		17	+5 V Reference output (GND)
		18	+5 V Reference output
		19	External Reference input (GND)
		20	External Reference input

Channel Assignments

The channel ON/OFF assignments for the NXC-VAI4 are described in the following table. Off = 50% voltage, and all channel assignments are mutually exclusive.

NXC-VAI4 Channel Assignments		
Channel	State	Function
Channel 1	ON	While channel 1 is ON, the voltage on Output 1 will ramp up at the "CURRENT OUTPUT 1 RAMP UP TIME" rate. The voltage ramp stops if the maximum is reached.
	OFF	Stops voltage ramping on Output 1 at current value.
Channel 2	ON	While channel 2 is ON, the voltage on Output 2 will ramp up at the "CURRENT OUTPUT 2 RAMP UP TIME" rate. The voltage ramp stops if the maximum is reached.
	OFF	Stops voltage ramping on Output 2 at current value.
Channel 3	ON	While channel 3 is ON, the voltage on Output 3 will ramp up at the "CURRENT OUTPUT 3 RAMP UP TIME" rate. The voltage ramp stops if the maximum is reached.
	OFF	Stops voltage ramping on Output 3 at current value.
Channel 4	ON	While channel 4 is ON, the voltage on Output 4 will ramp up at the "CURRENT OUTPUT 4 RAMP UP TIME" rate. The voltage ramp stops if the maximum is reached.
	OFF	Stops voltage ramping on Output 4 at current value.
Channel 5	ON	While channel 5 is ON, the voltage on Output 1 will ramp down at the "CURRENT OUTPUT 1 RAMP DOWN TIME" rate. The voltage ramp stops if the minimum is reached.
	OFF	Stops voltage ramping on Output 1 at current value.
Channel 6	ON	While channel 6 is ON, the voltage on Output 2 will ramp down at the "CURRENT OUTPUT 2 RAMP DOWN TIME" rate. The voltage ramp stops if the minimum is reached.
	OFF	Stops voltage ramping on Output 2 at current value.
Channel 7	ON	While channel 7 is ON, the voltage on Output 3 will ramp down at the "CURRENT OUTPUT 3 RAMP DOWN TIME" rate. The voltage ramp stops if the minimum is reached.
	OFF	Stops voltage ramping on Output 3 at current value.
Channel 8	ON	While channel 8 is ON, the voltage on Output 4 will ramp down at the "CURRENT OUTPUT 4 RAMP DOWN TIME" rate. The voltage ramp stops if the minimum is reached.
	OFF	Stops voltage ramping on Output 4 at current value.
Channel 9	ON	Reserved [do not use]
	OFF	Reserved [do not use]
Channel 10	ON	While channel 10 is ON, the voltage on Output 1 is set to 100%
	OFF	Sets Output 1 voltage to 50%.
Channel 11	ON	While channel 11 is ON, the voltage on Output 2 is set to 100%
	OFF	Sets Output 2 voltage to 50%.
Channel 12	ON	While channel 12 is ON, the voltage on Output 3 is set to 100%
	OFF	Sets Output 3 voltage to 50%.
Channel 13	ON	While channel 13 is ON, the voltage on Output 4 is set to 100%
	OFF	Sets Output 4 voltage to 50%.
Channel 14	ON	While channel 14 is ON, the voltage on Output 1 is set to 0%
	OFF	Sets Output 1 voltage to 50%.
Channel 15	ON	While channel 15 is ON, the voltage on Output 2 is set to 0%
	OFF	Sets Output 2 voltage to 50%.

NXC-VAI4 Channel Assignments (Cont.)		
Channel	State	Function
Channel 16	ON	While channel 16 is ON, the voltage on Output 3 is set to 0%
	OFF	Sets Output 3 voltage to 50%.
Channel 17	ON	While channel 17 is ON, the voltage on Output 4 is set to 0%
	OFF	Sets Output 4 voltage to 50%.
Channel 18	ON	While channel 18 is ON, the voltage on Output 1 is set to 75%
	OFF	Sets Output 1 voltage to 50%.
Channel 19	ON	While channel 19 is ON, the voltage on Output 2 is set to 75%
	OFF	Sets Output 2 voltage to 50%.
Channel 20	ON	While channel 20 is ON, the voltage on Output 3 is set to 75%
	OFF	Sets Output 3 voltage to 50%.
Channel 21	ON	While channel 21 is ON, the voltage on Output 4 is set to 75%
	OFF	Sets Output 4 voltage to 50%.
Channel 22	ON	While channel 22 is ON, the voltage on Output 1 is set to 25%
	OFF	Sets Output 1 voltage to 50%.
Channel 23	ON	While channel 23 is ON, the voltage on Output 2 is set to 25%
	OFF	Sets Output 2 voltage to 50%.
Channel 24	ON	While channel 24 is ON, the voltage on Output 3 is set to 25%
	OFF	Sets Output 3 voltage to 50%.
Channel 25	ON	While channel 25 is ON, the voltage on Output 4 is set to 25%
	OFF	Sets Output 4 voltage to 50%.

NXC-VAI4 Output Level Assignments

NXC-VAI4 Output Level Assignments	
Level	Description
1	8 bit field; sets voltage on Output 1 to the value commanded. The range is 0-255. Conflicts with channels 1, 5, 10, 14, 18, 22.
2	8 bit field; sets voltage on Output 2 to the value commanded. The range is 0-255. Conflicts with channels 2, 6, 11, 15, 19, 23.
3	8 bit field; sets voltage on Output 3 to the value commanded. The range is 0-255. Conflicts with channels 3, 7, 12, 16, 20, 24.
4	8 bit field; sets voltage on Output 4 to the value commanded. The range is 0-255. Conflicts with channels 4, 8, 13, 17, 21, 25.
5	8/16 bit field; commands that Output 1 be set to "CURRENT OUTPUT 1 SPEED" of the appropriate polarity until the voltage read at Input 1 is within "INPUT 1 MAXIMUM DEVIATION" of this value. Conflicts with channels 1, 5, 10, 14, 18, 22.
6	8/16 bit field; commands that Output 2 be set to "CURRENT OUTPUT 2 SPEED" of the appropriate polarity until the voltage read at Input 2 is within "INPUT 2 MAXIMUM DEVIATION" of this value. Conflicts with channels 2, 6, 11, 15, 19, 23.
7	8/16 bit field, commands that Output 3 be set to "CURRENT OUTPUT 3 SPEED" of the appropriate polarity until the voltage read at Input 3 is within "INPUT 3 MAXIMUM DEVIATION" of this value. Conflicts with channels 3, 7, 12, 16, 20, 24.
8	8/16 bit field, commands that Output 4 be set to "CURRENT OUTPUT 4 SPEED" of the appropriate polarity until the voltage read at Input 4 is within "INPUT 4 MAXIMUM DEVIATION" of this value. Conflicts with channels 4, 8, 13, 17, 21, 25.

NXC-VAI4 Input Level Assignments

NXC-VAI4 Input Level Assignments	
Level	Description
1	8 bit field, returns the current output voltage code for Output 1 (range= 0 to 255).
2	8 bit field, returns the current output voltage code for Output 2 (range= 0 to 255).
3	8 bit field, returns the current output voltage code for Output 3 (range= 0 to 255).
4	8 bit field, returns the current output voltage code for Output 4 (range= 0 to 255).
5	8/16 bit field, returns the current input voltage for Input 1 (range= 0 to 255 or 0-65535, depending on the ADMODE setting. See the AD MODE Send Command for details).
6	8/16 bit field, returns the current input voltage for Input 2 (range= 0 to 255 or 0-65535, depending on the ADMODE setting. See the AD MODE Send Command for details).).
7	8/16 bit field, returns the current input voltage for Input 3 (range= 0 to 255 or 0-65535, depending on the ADMODE setting. See the AD MODE Send Command for details).).
8	8/16 bit field, returns the current input voltage for Input 4 (range= 0 to 255 or 0-65535, depending on the ADMODE setting. See the AD MODE Send Command for details).).

Programming Information

These NetLinx Send_Commands control the NXC-VAI4:

NXC-VAI4 Send_Commands	
Command	Description
AD MODE Sets the format for data reporting to either 8 or 10 significant bits (16 bit format with 10 significant bits).	Even though the output is specified in the command, the format change really applies to the corresponding input. Input level changes and commanded positions are in this format. The reporting of the output levels is unaffected. The default format is 8 bits. Syntax: <pre>SEND_COMMAND <DEV>, 'AD MODE <OUTPUT> 8 10'</pre> Variable: OUTPUT: Any Output ('1', '2', '3', '4') Examples: <pre>SEND_COMMAND <DEV>, 'AD MODE 2 8'</pre> Sets the reporting format for Input 2 to 8 bits. (0-255) <pre>SEND_COMMAND <DEV>, 'AD MODE 1 10'</pre> Sets the input reporting format for Input 1 to 10 significant bits (0 - 65535)
DEFAULT Sets all card settings (<i>except for calibration</i>) back to original factory settings.	Syntax: <pre>SEND_COMMAND <DEV>, 'DEFAULT'</pre>
DEFAULT ALL Sets all card settings back to original factory settings.	Syntax: <pre>SEND_COMMAND <DEV>, 'DEFAULT ALL'</pre>

NXC-VAI4 Send_Commands (Cont.)	
Command	Description
<p>GAS Sets the slowdown distance and slowdown speed.</p>	<p>When these variables have been set, and a GL command is in progress, the speed output on Output <x> will be reduced to that specified when the position as read on Output <x+4> is within the distance specified away from the target position.</p> <p>Syntax: SEND_COMMAND <DEV>, 'G<OUTPUT>A<DISTANCE>S<SPEED>'</p> <p>Variables: OUTPUT: Any Output '1', '2', '3', or '4' DISTANCE: 0-127 SPEED: 0-127</p> <p>Example: SEND_COMMAND <DEV>, 'G1A127S127'</p> <p>Sets Output 1 slowdown distance to 127 (max) at full speed.</p>
<p>GD Sets the maximum allowable deviation of final servo position when executing the GL command.</p>	<p>The level of the specified input or output will only be reported when a change greater than this deviation occurs.</p> <p>Deviation 0 is most accurate, but can have some oscillation, so the default is 2, i.e. the position as read at corresponding input I/O <x+4> can be within +/-2 from the specified position.</p> <p>Syntax: SEND_COMMAND <DEV>, 'G<I/O>D<DEVIATION>'</p> <p>Variables: I/O: Any input or output ('1', '2', '3', '4', '5', '6', '7', '8') DEVIATION: Number between 0 and 127 (default = 2)</p> <p>Example: SEND_COMMAND <DEV>, 'G1D10'</p> <p>Sets I/O 1 servo output to 10.</p>
<p>GL This command puts the card in servo (positional) control mode.</p>	<p>The range of the position is 0-255 (if AD MODE is set to '8'), or 0-65535 (if AD MODE is set to '10'). See AD MODE earlier in this section for details.</p> <p>Position 0 is the low end of the potentiometer (lowest voltage); position 255 (or 65535) is the high end of the potentiometer (highest voltage) with 128 (or 32768) as the middle of the range.</p> <p>Syntax: SEND_COMMAND <DEV>, 'G<OUTPUT>L<POSITION>'</p> <p>Variables: I/O: Any Output ('1', '2', '3', '4') POSITION: Number between 0-255 or 0-65535 (depends on AD MODE)</p> <p>Example (Assuming the current position is 0): SEND_COMMAND <DEV>, 'G1L255'</p> <p>Sets Output 1 to "CURRENT OUTPUT 1 SPEED" (positive) and waits until Input 1 reads within "OUTPUT 1 MAXIMUM DEVIATION" of 255 and then resets the output to zero speed. The speed output may have a more complex profile than as set by the "GAS" command.</p>

NXC-VAI4 Send_Commands (Cont.)	
Command	Description
<p>GS Sets the speed variable to be used for future positional (GL) commands.</p>	<p>The change of speed takes place immediately even if a positional change operation is currently in progress. The voltage output for speed 0 (i.e. when no motion is desired) is at the mid-point between the Min and Max output voltages. The positive speed 127 is the max and negative speed 127 is the min. Other speeds are scaled proportionately.</p> <p>Syntax: SEND_COMMAND <DEV>, 'G<OUTPUT>S<SPEED>'</p> <p>Variable: I/O: Any Output ('1', '2', '3', '4') SPEED: A fixed output value in the range of 0 (slowest)-127 (fastest - default)</p> <p>Example: SEND_COMMAND <DEV>, 'G1S64' Sets Output 1 servo speed to 64 (50%).</p>
<p>LEVOFF The NXC-VAI4 will not transmit any level value messages after the receipt of this command until the receipt of the LEVON command.</p>	<p>Syntax: SEND_COMMAND <DEV>, 'LEVOFF'</p>
<p>LEVON The NXC-VAI4 will not transmit any level value messages until after the receipt of this command.</p>	<p>This command is sent automatically when the CREATE_LEVEL command is executed.</p> <p>Syntax: SEND_COMMAND <DEV>, 'LEVON'</p>
<p>PC Sets the shape of the Output <x> voltage ramps.</p>	<p>Syntax: SEND_COMMAND <DEV>, 'P<OUTPUT>C<CURVE>'</p> <p>Variables: OUTPUT: Any Output ('1', '2', '3', or '4') CURVE: 'N' - Normal linear 'L' - Logarithmic 'I' - Inverted logarithmic</p> <p>Example: SEND_COMMAND <DEV>, 'P1CL' Sets "CURRENT OUTPUT 1 RAMP CURVE" to logarithmic.</p>

NXC-VAI4 Send_Commands (Cont.)	
Command	Description
<p>PE</p> <p>Selects which voltage reference (if any) is to be used for scaling of the output voltage.</p>	<p>The specified output will then remain proportional to the specified input.</p> <p>Syntax:</p> <pre>SEND_COMMAND <DEV>, 'P<OUTPUT>E<REFERENCE SELECTION> B U'</pre> <p>Variables:</p> <p>OUTPUT: any Output ('1', '2', '3', or '4')</p> <p>Reference selection:</p> <ul style="list-style-type: none"> 'N' - Normal/None: Uses no reference scaling. 'E' - External: Use the External Reference input to scale the output. 'I' - Input: Use the corresponding <x+4> input as the reference for the output. <p>BIU: Bipolar or Unipolar (has no meaning for reference selection 'N')</p> <p>Unipolar mode sets the voltage range to between 0V and +reference voltage.</p> <p>Bipolar mode sets the output voltage range to between -reference voltage and +reference voltage.</p> <p>Examples:</p> <pre>SEND_COMMAND <DEV>, 'P1EN'</pre> <p>Sets Output 1 to use no reference (MIN/MAX limits are used instead.).</p> <pre>SEND_COMMAND <DEV>, 'P3EEU'</pre> <p>Sets Output 3 to use the External Reference input for scaling. The output voltages will range from 0 to the external reference voltage.</p> <pre>SEND_COMMAND <DEV>, 'P3EIB'</pre> <p>Sets Output 3 to use Input 7 for scaling. The output voltages will range from -input reading to +input reading.</p>
<p>PL</p> <p>Ramps the specified output from its current level value to the specified level value or specified percentage of maximum at the rate specified by "CURRENT OUTPUT <x> RAMP UP TIME" or optionally in the specified amount of time.</p>	<p>Syntax:</p> <pre>SEND_COMMAND <DEV>, 'P<OUTPUT>L<LEVEL VALUE> [T<TIME>]'</pre> <p>Variables:</p> <p>OUTPUT: Any Output ('1', '2', '3', or '4')</p> <p>LEVEL VALUE: 0 - 255 or 0 - 100% (where 0 is low voltage)</p> <p>TIME (optional): 0 - 255 in 0.1 second increments</p> <p>Examples:</p> <pre>SEND_COMMAND <DEV>, 'P1L50%</pre> <p>Ramps Output 1 from its current value to 50% (mid voltage level) at the "CURRENT OUTPUT 1 RAMP RATE".</p> <pre>SEND_COMMAND <DEV>, 'P2L255T30'</pre> <p>Ramps Output 2 to maximum voltage level in 3 seconds.</p>

NXC-VAI4 Send_Commands (Cont.)	
Command	Description
<p>PN</p> <p>Sets the value of either the minimum output voltage allowed for an output, or the minimum position voltage expected for an input.</p>	<p>Voltage settings are rounded to the nearest D/A or A/D code. Voltage settings for Outputs are absolute levels and are unaffected by any software scaling functions. Negative voltages are not valid for Input 3.</p> <p>Syntax: SEND_COMMAND <DEV>, 'P<I/O>N<LEVEL VALUE>'</p> <p>Variables: I/O: Any input or output ('1','2','3','4','5','6','7','8') LEVEL VALUE: -12.000V to +12.000V</p> <p>Examples: SEND_COMMAND <DEV>, 'P1N5.023V' Sets the minimum output level for Output 1 to 5.023V. SEND_COMMAND <DEV>, 'P1N-5.023V' Sets the minimum output level for Output 1 to -5.023V. SEND_COMMAND <DEV>, 'P7N5.023V' Sets the minimum of the expected input range for Input 7 to 5.023V.</p>
<p>PR</p> <p>Sets the CURRENT OUTPUT <x> RAMP UP TIME and/or CURRENT OUTPUT <x> RAMP DOWN TIME of the specified Output where TIME is the time to ramp the full range.</p>	<p>It can be set to ramp both down to up and up to down or just down to up or just up to down.</p> <p>Syntax: SEND_COMMAND <DEV>, 'P<OUTPUT>R<TIME> [U D]'</p> <p>Variables: OUTPUT: Any Output '1', '2', '3', or '4' TIME: 0 - 255 in 0.1 second increments U/D: Ramp Up (U) or Down (D)</p> <p>Examples: SEND_COMMAND <DEV>, 'P1R25' Sets CURRENT OUTPUT 1 RAMP UP TIME" and "CURRENT OUTPUT 1 RAMP DOWN TIME" to 2.5 seconds each for full range travel. SEND_COMMAND <DEV>, 'P2R75U' Sets CURRENT OUTPUT 2 RAMP UP TIME to 7.5 seconds for full range travel, CURRENT OUTPUT 2 RAMP DOWN TIME remains unchanged. SEND_COMMAND <DEV>, 'P2R50D' Sets "CURRENT OUTPUT 2 RAMP DOWN TIME" to 5 seconds for full range travel; "CURRENT OUTPUT 2 RAMP UP TIME" remains unchanged.</p>
<p>PU</p> <p>Sets the level to which this Output is set immediately after power-up and before any Output is commanded.</p>	<p>Syntax: SEND_COMMAND <DEV>, 'P<OUTPUT>U<LEVEL VALUE>'</p> <p>Variables: OUTPUT: Any Output ('1', '2', '3', or '4') LEVEL VALUE: 0-255</p> <p>Example: SEND_COMMAND <DEV>, 'P1U127' Sets the power up output level for Output 1 to 127.</p>

NXC-VAI4 Send_Commands (Cont.)	
Command	Description
<p>PX Sets the value of "I/O <x> MAXIMUM" which is either the maximum output voltage allowed for an Output, or the maximum position voltage expected for an Input.</p>	<p>Voltage settings are rounded to the nearest D/A or A/D code. Voltage settings are absolute levels and are unaffected by any scaling functions. Negative voltages are not valid for Inputs.</p> <p>Syntax: SEND_COMMAND <DEV>, 'P<I/O>X<LEVEL VALUE>'</p> <p>Variables: I/O: Any input or output ('1', '2', '3', '4', '5', '6', '7', '8') LEVEL VALUE: 12.000V to +12.000V</p> <p>Examples: SEND_COMMAND <DEV>, 'P1X5.023V' Sets the maximum output level for Output 1 to 5.023V. SEND_COMMAND <DEV>, 'P7X5.023V' Sets the maximum of the expected input range for Input 7 to 5.023V.</p>
<p>PZ Sets one of the two "set point" variables "I/O <x> SET POINT HIL" (high or low).</p>	<p>These variables are used to calculate calibration parameters for I/O <x> (input or output). Receiving this command with no voltage specified returns the specified set point to the default value.</p> <p>Syntax: SEND_COMMAND <DEV>, 'P<I/O>Z<VOLTAGE>H L'</p> <p>Variables: I/O: Any input or output ('1', '2', '3', '4', '5', '6', '7', '8' plus '0' for EREF) VOLTAGE: The current actual/measured voltage at the I/O.</p> <p>Examples: SEND_COMMAND <DEV>, 'P1Z0.5VL' Creates a low-end calibration point associating the current D/A code with 0.5 volts. SEND_COMMAND <DEV>, 'P1Z11.5VH' Creates a high-end calibration point associating the current D/A code with 11.5 volts. SEND_COMMAND <DEV>, 'P0Z0.1VL' Creates a low-end calibration point associating the current EREF A/D code with 0.1 volts. SEND_COMMAND <DEV>, 'P1ZL' Returns the Output 1 lower set point to its default.</p>

NXC-VOL4 Volume Control Card

The NXC-VOL4 Volume Control Card (**FG2024**) provides four discrete volume control channels with LED feedback. The volume control channels can be programmed for mono or stereo operation, and balanced or unbalanced audio connections. It supports programmable audio levels, audio mute, variable ramp speeds and preset levels. Use the on-board jumpers to set the gain/attenuation (Unity, Pro level (+4dBu) to Consumer level (-10dBu) conversion, or Consumer level to Pro level on each channel). FIG. 8 shows the VOL4 card.

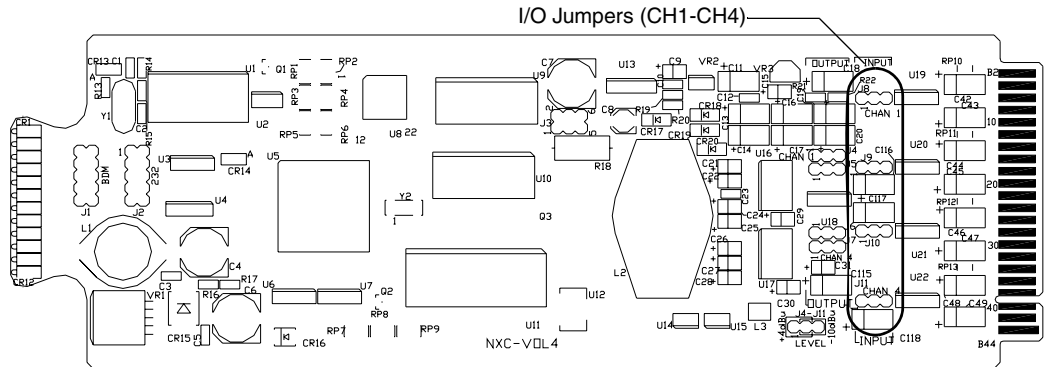

FIG. 8 NXC-VOL4 Volume Control card

Specifications

NXC-VOL4 Specifications	
Power Requirements	197 mA @ 12 VDC
Volume 1-4	Four volume channels
Status 1-4 (3 LEDs per channel)	<ul style="list-style-type: none"> Yellow LED shows level-up/down activity Red LED shows mute mode <p>LED 1: Channel 1 RAISE (yellow) LED 2: Channel 1 LOWER (yellow) LED 3: Channel 1 MUTE (red) LED 4: Channel 2 RAISE (yellow) LED 5: Channel 2 LOWER (yellow) LED 6: Channel 2 MUTE (red) LED 7: Channel 3 RAISE (yellow) LED 8: Channel 3 LOWER (yellow) LED 9: Channel 3 MUTE (red) LED 10: Channel 4 RAISE (yellow) LED 11: Channel 4 LOWER (yellow) LED 12: Channel 4 MUTE (red)</p>

NXC-VOL4 Specifications (Cont.)	
Gain jumpers 1-4	<ul style="list-style-type: none"> • Unity Maximum Input Level: +10dBm • Pro level to Consumer level conversion (attenuation of +4dBu IN to -10dBu OUT) Maximum Input Level: +10dBm • Consumer level to Pro level conversion (gain of -10dBu IN to +4dBu OUT) Maximum Input Level: +6dBm
Connections/wiring	Two 10-pin 3.5 mm captive-screw terminals
Audio Specifications	<ul style="list-style-type: none"> • Frequency response of 15 Hz - 25 KHz. • THD less than .005% at nominal output level. • S/N ratio greater than 100 dB (IHF A). • Crosstalk less than 80 dB. • Logarithmic attenuation range of 95 dB

Pinouts, Signals, and Functions

NXC-VOL4 Pinouts, Signals, and Functions			
Pin	Signal	Balanced Function	Unbalanced Function
Channel 1			
1	GND	Audio GND	Audio GND
2	Input 1+	Audio IN	Audio IN
3	Input 1-	Audio IN	Audio GND
4	Output 1+	Audio OUT	Audio OUT
5	Output 1-	Audio OUT	no connection
Channel 2			
6	GND	Audio GND	Audio GND
7	Input 2+	Audio IN	Audio IN
8	Input 2-	Audio IN	Audio GND
9	Output 2+	Audio OUT	Audio OUT
10	Output 2-	Audio OUT	no connection
Channel 3			
11	GND	Audio GND	Audio GND
12	Input 3+	Audio IN	Audio IN
13	Input 3-	Audio IN	Audio GND
14	Output 3+	Audio OUT	Audio OUT
15	Output 3-	Audio OUT	no connection
Channel 4			
16	GND	Audio GND	Audio GND
17	Input 4+	Audio IN	Audio IN
18	Input 4-	Audio IN	Audio GND
19	Output 4+	Audio OUT	Audio OUT
20	Output 4-	Audio OUT	no connection

NXC-VOL4 Connections/Wiring

The NXC-VOL4 card contains four audio volume control channels. Each line-level channel is isolated from system ground and can be configured for balanced or unbalanced line operation. It supports programmable audio levels, audio mute, variable ramp speeds, and preset levels. Each audio channel's input to output gain ratio is adjustable via the on-board jumpers shown in FIG. 8 on page 41.



- Unity (jumper not installed)
- Gain (-10 dB Input level/+4 dB Output level setting on pins 1 and 2)
- Attenuate (+4 dB Input level/-10 dB Output level setting on pins 3 and 4)

NXC-VOL4 Channel Assignments

The NXC- VOL4 channel assignments are listed in the following table. This card has 2 ports with 2 audio "channels" in each port. The two audio "channels", which can be used as right and left, should not be confused with the *channel assignments*, which are sent to and from the card.

NXC-VOL4 Channel Assignments (per port)		
Port 1 Channel:	Port 2 Channel:	Description
1	1	While channel is on, ramps the volume on audio channels 1 and 2 up (increase).
2	2	While channel is on, ramps the volume on audio channels 1 and 2 down (decrease).
3	3	While channel is on, the volume on audio channels 1 and 2 are muted (lowest volume); when channel is off, the volume levels are restored to their previous levels.
4	4	While channel is on, ramps the volume on audio channel 1 up (increase).
5	5	While channel is on, ramps the volume on audio channel 1 down (decrease).
6	6	While channel is on, the volume on audio channel 1 is muted (lowest volume); when channel is off, the volume level is restored.
7	7	While channel is on, ramps the volume for audio channel 2 up (increase).
8	8	While channel is on, ramps the volume for audio channel 2 down (decrease).
9	9	While channel is on, volume for audio channel 2 is muted (lowest volume); when channel is off, the volume level is restored.

Ramping a volume channel while the mute channel is on will not automatically turn off the mute channel but the ramping will still occur; the volume change will be noticed when the mute channel is turned off. For setting ramp rates and presets, refer to the *Programming Information* section on page 45.

NXC-VOL4 Levels

Volume (audio) channels 1 and 2 use levels 1 and 2 respectively. For reading current volume levels and displaying bargraphs see *CREATE_LEVEL* and *SEND_LEVEL* . The two levels associated with each port of the NXC-VOL4 Control Card are listed in the table below:

NXC-VOL4 Levels			
Port 1		Port 2	
Level	Description	Level	Description
1	Output #1	1	Output #3
2	Output #2	2	Output #4

CREATE_LEVEL

This keyword creates an association between a specified level of a device and a variable that will contain the value of the level. This can only appear in the *DEFINE_START* section of the program.

```
CREATE_LEVEL DEV, Level, Value
```

Parameters:

- DEV: The device from which to read the level.
- Level: The level of the device to read.
- Value: Variable in which to store the level value.
- DevLev: A DEVLEV structure.
- Value: Variable in which to store the level value *CREATE_LEVEL* DevLev, Value.

During execution of the program, NetLinx continuously updates the variable to match the level that it represents.

SEND_LEVEL

This keyword sends a value to a specific level on a NetLinx device/port. The syntax follows any one of the four following examples:

```
SEND_LEVEL DEV, Level, Value
SEND_LEVEL DEV[ ], Level, Value
SEND_LEVEL DEVLEV, Value
SEND_LEVEL DEVLEV[ ], Value
```

Parameters:

- DEV: Device containing the specified level
- Level: Number of the level to receive the new value
- Value: New level value
- DEV[]: Device array (each device contains the specified level)
- DEVLEV: Device-level to receive the new value
- DL[]: Device-level array (each will receive the new value)

Programming Information

These NetLinx Send_Commands control the NXC-VOL4.

NXC-VOL4 Send_Commands	
Command	Description
<p>PL</p> <p>Ramps specified (audio) channel(s) from current level to a specified preset level or percentage at the current rate or optionally in a specified amount of time.</p>	<p>Syntax:</p> <pre>SEND_COMMAND <DEV>, 'P<Output Channel>L<Level> [T<Time>]'</pre> <p>Variables:</p> <ul style="list-style-type: none"> Output Channel: Target audio channel number (0-2). Output channel 0 means both channels 1 and 2. Level: Target level (0-255 or 0-100%). Level 0 is lowest volume (same as mute) and 255 (or 100%) is maximum volume. Time: Specifies the amount of time (in .10-second increments) that it takes to ramp the specified audio channel to the specified level. <p>Example:</p> <pre>SEND_COMMAND MYDEVICE, 'POL50%'</pre> <p>Ramps both audio channels on MYDEVICE to 50% volume at the current ramp rate.</p>
<p>PR</p> <p>Sets the ramp rate of the specified channel(s) where Time is the time to ramp the full range both down to up and up to down or optionally just down to up or just up to down.</p>	<p>If Time is set to 50, it takes 5 seconds to ramp through the full range of 0 to 255 (0-100%). It would take 2.5 seconds to ramp through half of the range and so on.</p> <p>Syntax:</p> <pre>SEND_COMMAND <DEV>, 'P<Output Channel>R<Time> [U D]'</pre> <p>Variables:</p> <ul style="list-style-type: none"> Output Channel: Target channel number (0-2). Output channel 0 means both channels 1 and 2. Time: Specifies the amount of time (in .10-second increments) that it would take to ramp the full range of 0-100% (down to up and up to down or optionally just down to up or just up to down). UID: Ramps the specified channel(s) from down to up (U) or from up to down (D). <p>Example:</p> <pre>SEND_COMMAND MYDEVICE, 'POR50''</pre> <p>Sets ramp rate of audio channels 1 and 2 to five seconds full range from down to up and up to down.</p>



AMX reserves the right to alter specifications without notice at any time.

ARGENTINA • AUSTRALIA • BELGIUM • BRAZIL • CANADA • CHINA • ENGLAND • FRANCE • GERMANY • GREECE • HONG KONG • INDIA • INDONESIA • ITALY • JAPAN
LEBANON • MALAYSIA • MEXICO • NETHERLANDS • NEW ZEALAND • PHILIPPINES • PORTUGAL • RUSSIA • SINGAPORE • SPAIN • SWITZERLAND • THAILAND • TURKEY • USA
ATLANTA • BOSTON • CHICAGO • CLEVELAND • DALLAS • DENVER • INDIANAPOLIS • LOS ANGELES • MINNEAPOLIS • PHILADELPHIA • PHOENIX • PORTLAND • SPOKANE • TAMPA
3000 RESEARCH DRIVE, RICHARDSON, TX 75082 USA • 800.222.0193 • 469.624.8000 • 469-624-7153 fax • 800.932.6993 technical support • www.amx.com

060-004-2313 7/05 ©2005 AMX Corporation. All rights reserved. AMX, the AMX logo, the building icon, the home icon, and the light bulb icon are all trademarks of AMX Corporation. AMX reserves the right to alter specifications without notice at any time. *In Canada doing business as Panja Inc.

Last Revision: 11/7/05