



BG-M SERIES

MODULAR MIXER/ AMPLIFIERS

BG-1015

BG-1030

BG-1060

BG-1120

TOA BG-M SERIES MIXER/AMPLIFIERS are ideal for a wide variety of installed sound applications such as paging, music distribution and messaging-on-hold. Engineered with unmatched TOA quality and reliability, the versatile BG-M Series is loaded with useful features and an essential tool for any sound system designer or contractor.

The BG-M Series Mixer/Amplifiers are comprised of four models, **BG-1015** (15 W), **BG-1030** (30 W), **BG-1060** (60 W) and **BG-1120** (120 W), all built with a compact, space-saving chassis design. Input channels include: microphone and telephone paging inputs, program and auxiliary music inputs plus a flexible module slot compatible with industry-standard TOA 900 Series modules which have an extensive array of features and connector types. Outputs include transformer-isolated 25 V, 70 V and 4 ohm, balanced, line-level Music-On-Hold plus a 1 watt output for driving an additional 8 ohm speaker zone.

Muting modes include an Auto-Mute function for voice-activated paging override of the BGM channels without interrupting the MOH output. External mute terminals allow you to activate the mute function with an external switch-closure.

Other features include bass/treble controls, insert jacks and Signal, Clip, and Power indicators. Built-in protection circuitry and an AC mains circuit breaker ensure long life and outstanding reliability.

Accessories include optional rack-mount kits and volume control security knobs to protect settings.

The BG-M Series is UL and cUL listed with competitive pricing and a five-year warranty.



HIGHLIGHTS

- **Compact Five Channel Mixer/Amplifiers** for paging, background/foreground music distribution and music/messaging-on-hold.
- **Proven TOA Quality and Reliability**
- **Engineered for High Performance** with wide frequency response, very low noise and distortion, and excellent output regulation.
- **Four Models:**
BG-1015 (15 W), **BG-1030** (30 W)
BG-1060 (60 W), **BG-1120** (120 W)
- **900 Series Module Slot** with Page/BGM switch accepts most TOA plug-in modules for custom system configurations.
- **25 V, 70 V and 4 Ohm Speaker Outputs** with screw terminal connector and protective cover plate.
- **Microphone Page Input**, balanced, with screw terminal connector and 24 VDC phantom power.
- **Telephone Page Input**, balanced, transformer-isolated with screw terminal connector and switchable 600/10k ohm input impedance.
- **Program (PGM) Input**, balanced, with screw terminal connector.
- **Auxiliary (AUX) Input**, unbalanced, with dual-RCA jacks for convenient connection of stereo sources.
- **Music-On-Hold (MOH) Output**, balanced, with screw terminal connector.
- **Internal Signal Routing Jumpers** for assigning AUX/PGM and module to main and/or MOH outputs.
- **1 Watt Zone Output**, 8 ohm, with screw terminal connector.
- **Auto-Mute Function** allows voice-activated paging override of AUX/PGM and/or module without interrupting the MOH output.
- **Auto-Mute SENSE Control** for adjusting mute activation threshold.
- **Selectable Muting Modes** for versatile priority paging configurations.
- **External Mute Terminals** for activating mute function with external switch-closure.
- **Bass/Treble Tone Controls** affect only the AUX/PGM channels to the main speaker output.
- **Insert Jacks** for connecting external signal processor.
- **Signal, Clip, and Power Indicators** provide unit status.
- **Rear Panel AC Convenience Outlet** with circuit breaker for powering external equipment.
- **Turn-On Delay** disconnects output during power-up.
- **Over-current and Thermal Protection Circuitry** prevents potential damage from overloads, short-circuit and overheating.
- **AC Mains Circuit Breaker**
- **Volume Control Security Knobs Included (5)**
- **Optional Rack-Mount Kit**
- **UL / cUL Listed**
- **Five Year Warranty**

OPTIONAL ACCESSORIES

Plug-in Modules (see individual module specifications)

MB-1000 Rack-mount Kit (2 RU)

PF-511 Perforated Rack Panel (1 RU)

YA-920 Volume Control Security Knob

900 Series Module Guide available from <http://www.toaelectronics.com>



SPECIFICATIONS

BG-M SERIES
MODULAR MIXER/AMPLIFIERS

Tel: 800-733-7088
Fax: 800-733-9766
www.toaelectronics.com



Type	Five channel mixer/amplifier
Output Power	BG-1015: 15 W RMS, BG-1030: 30 W RMS, BG-1060: 60 W RMS, BG-1120: 120 W RMS
Frequency Response	50 - 20k Hz (± 3 dB)
Total Harmonic Distortion	0.05% at 1k Hz, rated output
Inputs	<p>Mic: -60 dBV, 600 Ω, electronically balanced, screw terminal, 24 VDC phantom power</p> <p>Tel: -20 dBV, 10k Ω/600 Ω, transformer-balanced, screw terminal</p> <p>Program: -10 dBV, 10k Ω, electronically-balanced, screw terminal</p> <p>Aux: -10 dBV, 47k Ω, unbalanced, 2 x RCA pin jack (stereo-sum)</p> <p>Module: Specifications dependent on module type.</p> <p>Power IN: 0 dBV, 10k Ω, unbalanced, RCA pin jack</p> <p>Mute: screw terminal</p>
Outputs	<p>Main: 4 Ω, 25 and 70 V, balanced, screw terminal</p> <p>Sub/Zone: 1 W / 8 Ω, unbalanced, screw terminal</p> <p>MOH: 0 dBV, 600 Ω, balanced, screw terminal</p> <p>Preamp OUT: 0 dBV, 600 Ω, unbalanced, RCA pin jack</p>
Output Regulation	Less than 2 dB, no load to full load
Muting/ Priority Override	Mic, Telephone, Module (Page mode) Over-ride of Auxiliary, Program, Module (BGM mode) Automute and/or External Switch Closure
External Mute Modes (activated with switch-closure)	<p>A: Mic, Tel, Module (Page mode) normally ON, no change with switch closure Aux, Program, Module (BGM mode) normally ON, activates to OFF with switch closure</p> <p>B: Mic, Tel, Module (Page mode) normally OFF, activates to ON with switch closure Aux, Program, Module (BGM mode) normally ON, activates to OFF with switch closure</p>
Module Slot	<p>Card edge connector connects to audio input and output points of TOA 900 Series modules. Use of Mute-type modules is not required in BG-M Series models. Mute function is determined by Module Mode switch.</p> <p>Module Mode Switch</p> <p>Page: module input signal mixes with Mic/Tel inputs and activates Auto-Mute function</p> <p>BGM: module input signal mixes with Aux and Program inputs and responds to Auto-Mute / External Mute functions</p>
Internal Jumper Settings	<p>Phantom Power (Mic input)</p> <p>Mic, Tel, Module (Page mode) Automute routing and assignment</p> <p>Aux, Program, Module (BGM mode) MOH/Zone routing</p>
Dynamic Range	Mic: 60 dB, Telephone: 75 dB, Program: 75 dB, Aux: 75 dB (Band Pass: 20 Hz - 20k Hz, with Tone Controls centered)
Tone Controls	<p>Bass: ± 10 dB at 100 Hz, Treble: ± 10 dB at 10k Hz</p> <p>Controls affect only Program, Auxiliary and Module (BGM mode) inputs</p>
Cooling Fan Speed	Variable by heat sink temperature (BG-1060 and BG-1120)
Indicators	Power, Signal, and Peak LEDs
Power Source	120 VAC, 60 Hz
Power Consumption (Rated output)	BG-1015: 50 W, BG-1030: 80 W, BG-1060: 160 W, BG-1120: 260 W
Protection	Self protection, with 1 AC circuit breaker (external)
Other Features	<p>AC Outlet, 3-pin grounding type</p> <p>Automatic electronic drive limiter</p> <p>Output disconnected for approx. 3 seconds after the unit is turned on</p>
Finish	Panel: ABS resin, black Case: Steel plate, black
Dimensions (W x H x D)	10.39" x 4.23" x 11.02" (264 x 107.4 x 280 mm)
Weight	BG-1015: 9.92 lbs (4.5 kg), BG-1030: 10.58 lbs (4.8 kg), BG-1060: 12.35 lbs (5.6 kg), BG-1120: 14.11 lbs (6.4 kg)
Accessories	5 x Volume Control Security Knobs: YA-920

APPLICATIONS

AV Rentals	Boardrooms	Hotels / Hospitality	Public Address
Airports	Business Music	Houses of Worship	Restaurants
Audio/Visual	Conference Facilities	Industrial / Warehouses	Retail Stores
Auditoriums / Theatres	Convenience Stores	Museums	Theme Parks
Banks	Educational Facilities	Music Distribution	Training Rooms
Bars / Lounges / Nightclubs	Fitness Clubs / Gymnasiums	Offices	



BG-M SERIES
MODULAR MIXER/AMPLIFIERS

Tel: 800-733-7088
Fax: 800-733-9766
www.toaelectronics.com

SPECIFICATIONS

DIMENSIONAL DRAWING

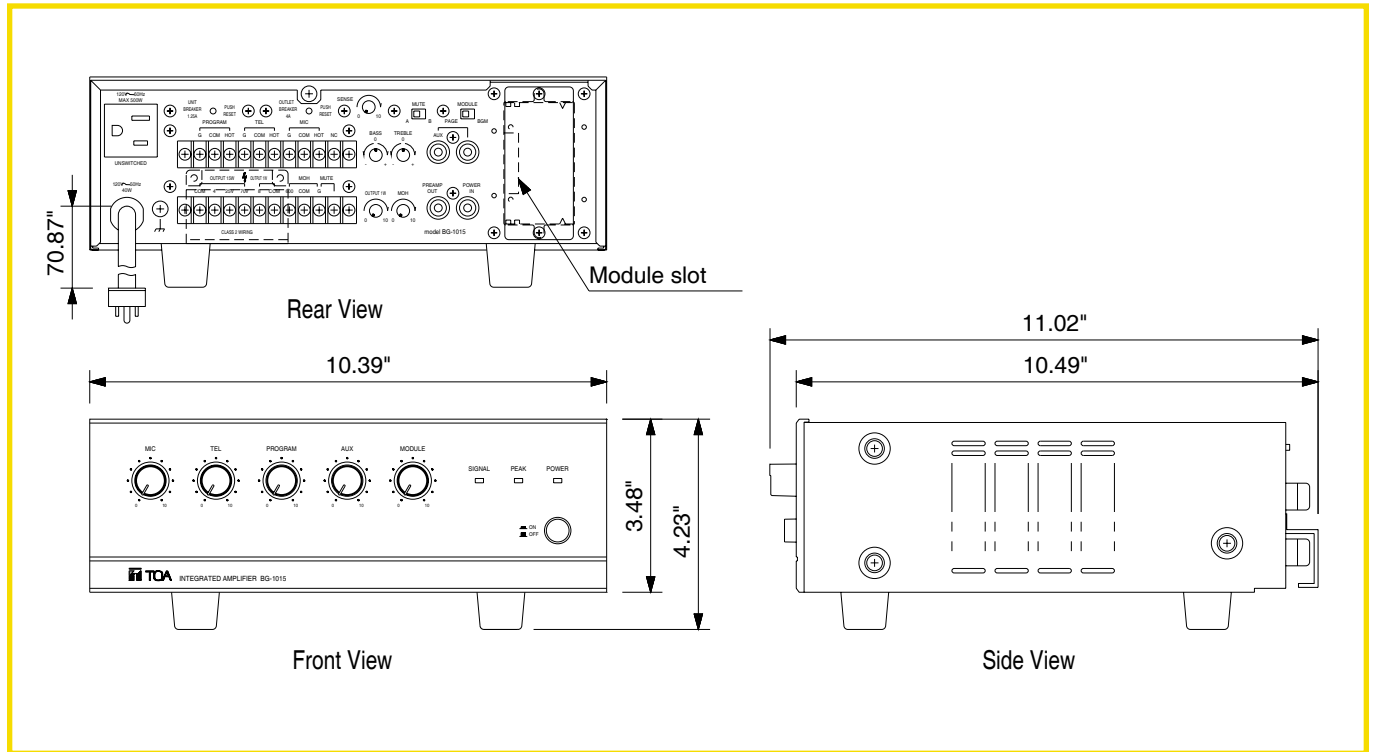

BLOCK DIAGRAM

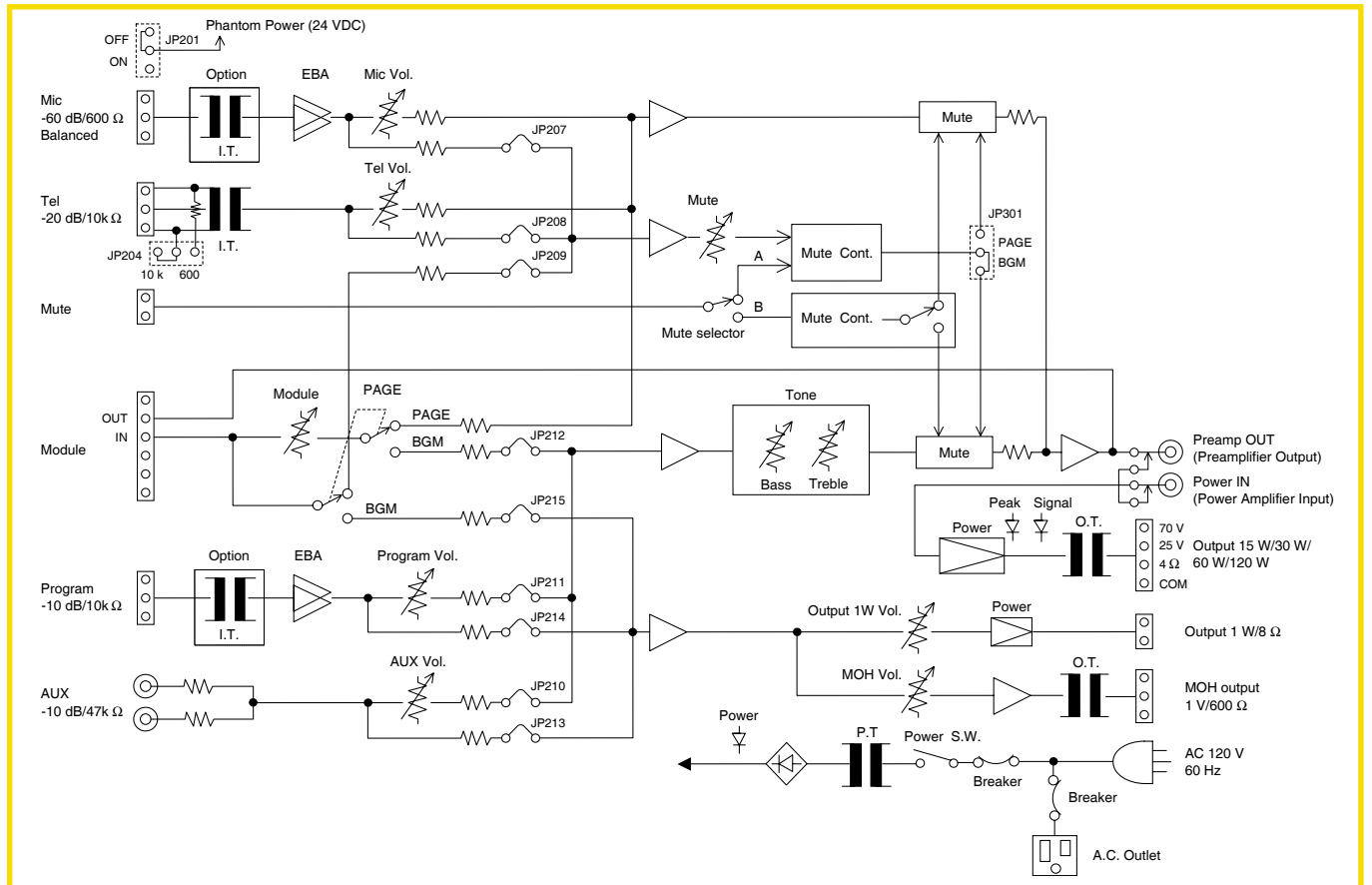



TOA ELECTRONICS, INC.
 601 GATEWAY BLVD., SUITE 300
 SOUTH SAN FRANCISCO, CA 94080
 TEL: 800-733-7088
 FAX: 800-733-9766
www.toaelectronics.com

BG-M SERIES MODULAR MIXER/ AMPLIFIERS



	Model	Description
Microphone Input Modules	M-01F	Microphone Input Module, Balanced, 200 Ω , Lo/Hi-Cut Filters, Female XLR
	M-01M	Same as M-01F with Male XLR
	M-01P	Same as M-01F with Phone Jack
	M-01S	Same as M-01F with Screw Terminals
	M-03P	Microphone Input Module, HiZ, Unbalanced, 50k Ω , Lo/Hi-Cut Filters, Phone Jack
	M-21S	Microphone Input Module, Balanced, 200 Ω , Lo/Hi-Cut Filters, Remote Vol. Control, Screw Terminals
	M-51F	Microphone Input Module, Balanced, 200 Ω , Lo-Cut Filter, Voice Gate, Female XLR
	M-51S	Same as M-51F with Screw Terminals
	M-61F	Microphone Input Module, Balanced, 200 Ω , Lo/Hi-Cut Filters, Compressor, Female XLR
	M-61S	Same as M-61F with Screw Terminals
Line Input Modules*	B-01F	Balanced Line Input Module, 10k Ω Transformer, Female XLR
	B-01S	Balanced Line Input Module, 10k Ω Transformer, Screw Terminals
	B-21S	Balanced Line Input Module, 10k Ω Transformer, Remote Volume Control, Screw Terminals
	L-01F	Line Matching Input Module, 600 Ω Transformer, Balanced, Female XLR
	L-01S	Same as L-01F with Screw Terminals
	U-01F	Line Input Module, Unbalanced, 220k Ω , Female XLR
	U-01P	Same as U-01F with Phone Jack
	U-01R	Same as U-01F with RCA Jack
	U-01S	Same as U-01F with Screw Terminals
	U-03R	Stereo Line Input Module, Lo/Hi-Cut Filters, Stereo Summing Dual RCA Jacks
	U-03S	Line Input Module, Lo/Hi-Cut Filters, Screw Terminals
	U-21S	Line Input Module, Unbalanced, 220k Ω , Remote Volume Control, Screw Terminals
U-61S	Line Input Module, Unbalanced, 220k Ω , Compressor, Screw Terminals	
Special Function Modules	E-03R	900 Series Processor Module for F-121C/CM Speakers, Dual RCA Jacks
	E-04R	900 Series Processor Module for H-1 Speakers, Dual RCA Jacks
	E-05R	900 Series Processor Module for H-2/H-2WP Speakers, Dual RCA Jacks
	E-06R	900 Series Processor Module for H-3/H-3WP Speakers, Dual RCA Jacks
	E-07S	900 Series Low Pass Filter Output Module for FB-100 and HB-1, Removable Terminal Block
	S-01S	Signal Generator Module, 1 kHz Sine Wave, Screw Terminals
	S-02S	Signal Generator Module, Buzzer/Yelp, Screw Terminals
	S-04S	Signal Generator Module, 8 Selectable Tones, Screw Terminals
	T-01S	Line Output Module, Balanced, 600 Ω , Screw Terminals
	T-02S	Line Input Module for Music-on-Hold, Unbalanced, 220k Ω Input, 600 Ω Balanced Output, Screw Terminals

* For Line Input Modules: Use "B" modules w/ transformer isolation for balanced/unbalanced sources. Use "L" modules only for 600 ohm impedance matching. Use "U" for unbalanced sources w/ short cables (≤ 15 feet).

Visit www.toaelectronics.com to download:

- BG-M Series Architect and Engineering Specifications
- BG-M Series Installation Manual
- BG-M Series CAD Files