

---

## S P E C F I L E

---

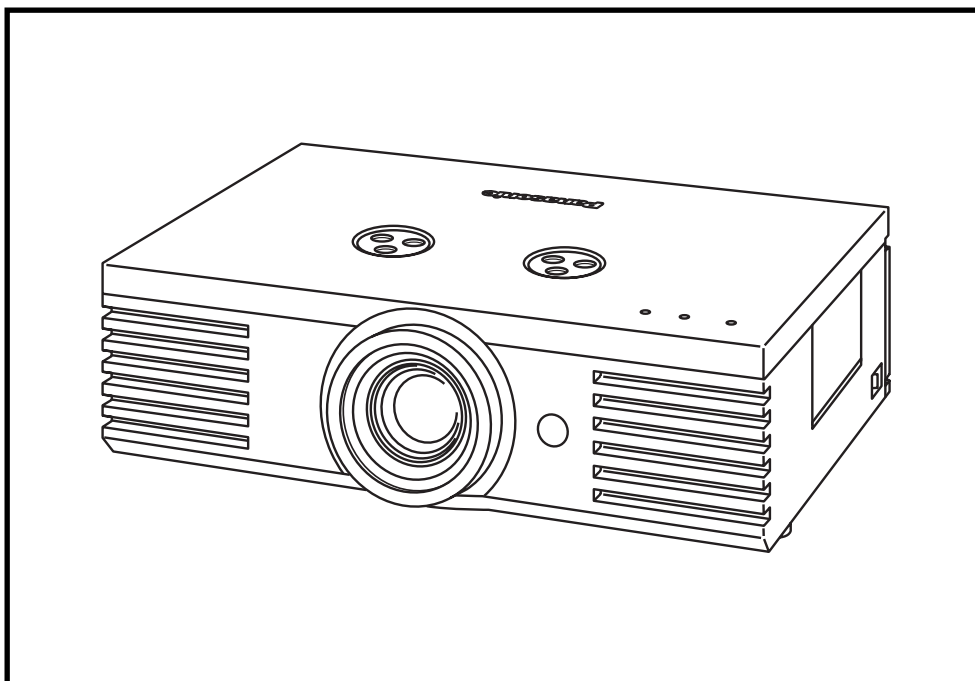

Product Number : **PT-AE1000E**

Product Name : Full High Definition Home Cinema Projector

**Specifications****Main Unit**

Power supply:		100–240 V AC, 50/60 Hz
Power consumption:		240 W (0.08 W in standby mode with fan stopped)
LCD*1 panel:	Panel size:	0.74 diagonal (16:9 aspect ratio)
	Display method:	Transparent LCD panel (x 3, R/G/B)
	Drive method:	Active matrix
	Pixels:	2,073,600 (1,920 x 1,080) x 3, total of 6,220,800 pixels
Lamp*2:		165 W UHM™ lamp
Lens:		Powered zoom/focus lens (1:1–1:2), F 1.9–3.2, f 22.4–44.8 mm
Screen size:		40–200 inches
Colours:		Full colour (1,073,741,824 colours)
Brightness:		1,100 lumens*3
Contrast:		11,000:1*3 (full on/full off)
Centre-to-corner uniformity ratio:		85 %
Resolution:	RGB:	1,400 x 1,050 pixels (1,600 x 1,200 pixels compatible, compression mode)
	Video:	560 TV lines
Scanning frequency:	RGB:	Horizontal: 30–70 kHz, Vertical: 50–87 Hz, Dot clock: 24–120 MHz
	YPbPr:	480i: fH 15.75 kHz; fV 60 Hz, 576i: fH 15.63 kHz; fV 50 Hz, 480p: fH 31.5 kHz; fV 60 Hz, 576p: fH 31.25 kHz; fV 50 Hz, 720/60p: fH 45 kHz; fV 60 Hz, 720/50p: fH 37.5 kHz; fV 50 Hz, 1080/60i: fH 33.75 kHz; fV 60 Hz, 1080/50i: fH 28.125 kHz; fV 50 Hz, 1080/24p: fH 27 kHz; fV 24 Hz, 1080/60p: fH 67.5 kHz; fV 60 Hz, 1080/50p: fH 56.3 kHz; fV 50 Hz
	S-Video/Video:	fH 15.75 kHz fV 60 Hz (NTSC, NTSC4.43, PAL-M, PAL60) fH 15.75 kHz fV 60 Hz (PAL, SECAM, PAL-N)
	SCART*5:	PAL/SECAM, RGB
Optical axis shift*4:		Horizontal: ±40%, vertical: ±100%
Keystone correction range:		Vertical: approx. ±30°
Installation:		Ceiling/floor, front/rear (menu selection)
OSD languages:		English, French, German, Spanish, Italian, Chinese, Korean, Russian, Swedish, Danish, Norwegian, Polish, Czech, Hungarian, Portuguese, Thai
Terminals:	HDMI IN:	19-pin x 2
	PC (RGB) IN:	D-sub HD 15-pin (female) x 1
	R, G, B:	0.7 Vp-p (1.0 Vp-p for Sync on G), 75 ohms
	HD/VD/SYNC:	TTL, high impedance (positive/negative polarity)
	COMPONENT IN:	RCA pin (Y, Pb, Pr) x 1
	Y:	1.0 p-p, 75 ohms
	Pb, Pr:	0.7 Vp-p, 75 ohms
	SCART IN:	21-pin x 1
	VIDEO IN:	RCA pin x 1, 1.0 Vp-p, 75 ohms
	S-VIDEO IN:	Mini DIN 4-pin x 1, Y: 1.0 Vp-p, C: 0.286 Vp-p, 75 ohms
	SERIAL IN:	D-sub 9-pin (RS-232C) x 1, for external control
Power cord length:		3 m (9'10")
Cabinet material:		PC + ABS
Dimensions (W x H x D):		460 x 130 x 300 mm (18-1/8" x 5-1/8" x 11-25/32")*5
Weight:		7.2 kg (15.9 lbs.)
Operating temperature:		0°–40°C (32°–104°F)
Operating humidity:		20%–80% (no condensation)

**Remote Control Unit**

Power supply:	3 V DC (AA battery x 2)
Operation range*6:	Approx. 7 m when operated from directly in front of the signal receptor 52 x 200 x 28.5 mm (2" x 6-15/16" x 7/8")
Dimensions (W x H x D):	170 g (6 oz.)

**Supplied Accessories**

Power cord  
Wireless remote control unit  
Batteries for remote control (UM-3 x 2)

**Optional Accessories**

Replacement lamp: ET-LAE1000  
Ceiling mount bracket: ET-PKE1000S  
Ceiling mount bracket for high ceilings: ET-PKX100  
Cable cover: ET-PCE1000

**Weights and dimensions shown are approximate.  
Specifications subject to change without notice.**

\*1: The projector uses a type of liquid crystal panel that typically consists of millions of pixels. This panel is built with very high-precision technology to provide the finest possible image. Occasionally, a few pixels may remain turned on (bright) or turned off (dark). Please note that this is an intrinsic characteristic of the manufacturing technology that affects all products using LCD technology.

\*2: The projector uses a high-voltage mercury lamp that contains high internal pressure. This lamp may break, emitting a large sound, or fail to illuminate, due to impact or extended use. The length of time that it takes for the lamp to break or fail to illuminate varies greatly depending on individual lamp characteristics and usage conditions.

\*3: In AI mode, with dynamic iris on.

\*4: Shift range is limited during simultaneous horizontal and vertical shifting.

\*5: Lens and legs not included.

\*6: Operation range differs depending on environments.

**Dimensions**

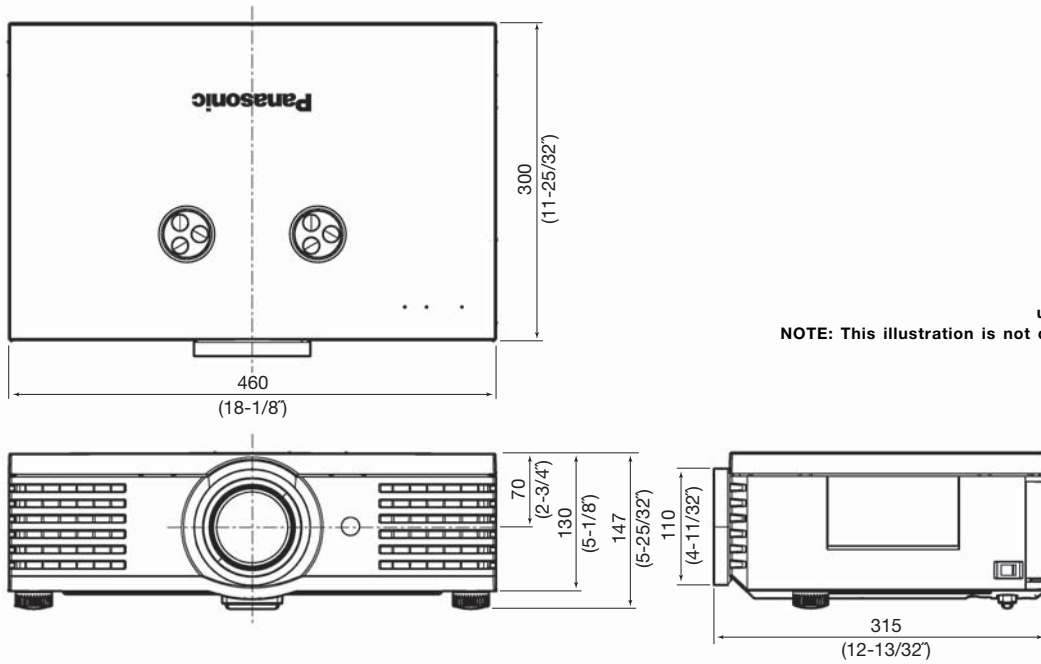

unit : mm (inch)  
NOTE: This illustration is not drawn to scale.

**Terminals**

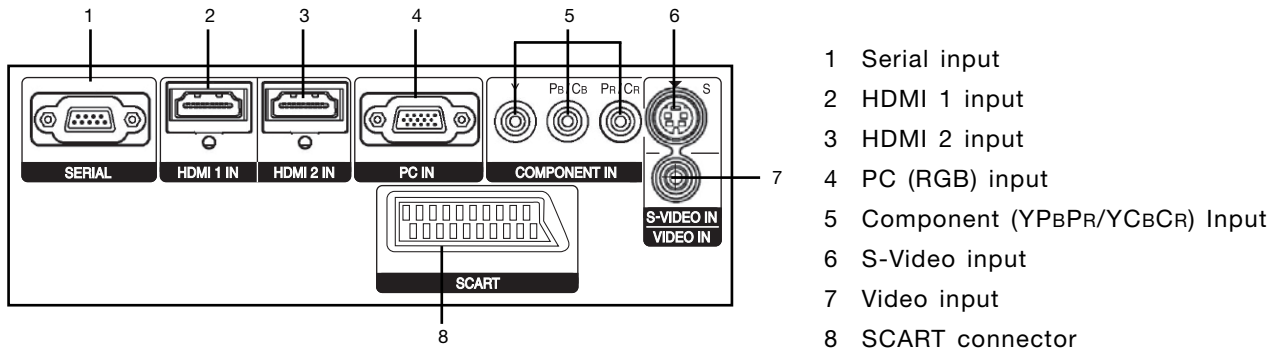

**PC (RGB) IN connector pin assignment**

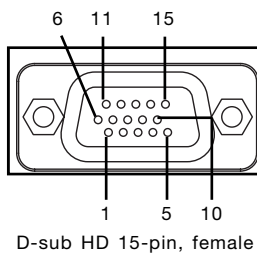

no.	signal	no.	signal	no.	signal
1	R	6	GND	11	GND
2	G	7	GND	12	NC
3	B	8	GND	13	HD/SYNC
4	GND	9	NC	14	VD
5	GND	10	GND	15	NC

Standard setting-up positions

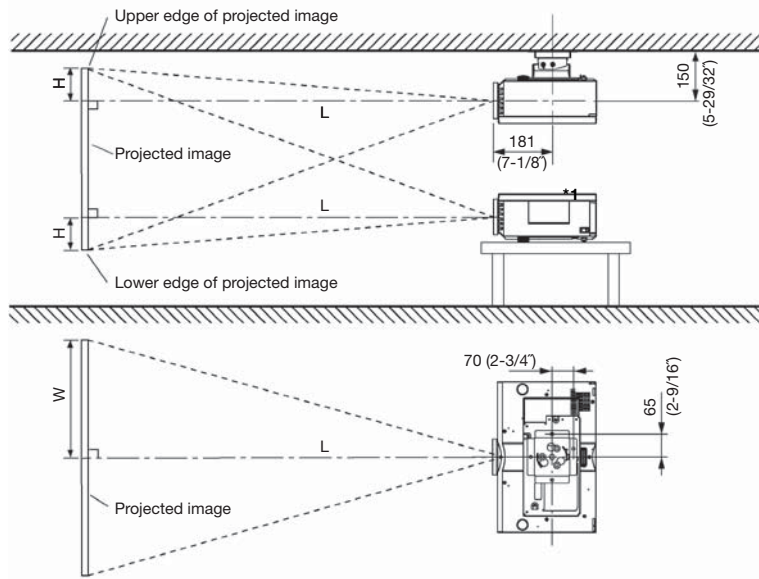

unit : mm (inch)

**NOTE:**  
 Illustrations show the projector installed using optional ceiling bracket ET-PKE1000S. This illustration is not drawn to scale. Values shown are approximate.

Projection distance (screen aspect ratio 16:9)

Projection size (16:9) Diagonal length	Projection distance (L)		Height from the edge of screen to centre of lens (E)	Width from the right edge of screen to centre of lens (W)
	Min (Wide)	Max (Telephoto)		
1.01 m / 40"	1.2 m / 3'11"	2.3 m / 7'7"	-0.25 m - 0.75 m / 9'8" - 2'6"	0.09 m - 0.80 m / 3.5" - 2'7"
1.52 m / 60"	1.8 m / 5'10"	3.5 m / 11'6"	-0.38 m - 1.13 m / 1'3" - 3'8"	0.14 m - 1.20 m / 5.5" - 3'11"
2.03 m / 80"	2.4 m / 7'10"	4.7 m / 15'5"	-0.50 m - 1.50 m / 1'8" - 4'11"	0.18 m - 1.60 m / 7" - 5'3"
2.54 m / 100"	3.0 m / 10'2"	6.0 m / 19'8"	-0.63 m - 1.87 m / 2'1" - 6'2"	0.23 m - 2.00 m / 9" - 6'7"
3.05 m / 120"	3.6 m / 11'10"	7.2 m / 23'7"	-0.75 m - 2.25 m / 2'6" - 7'5"	0.27 m - 2.40 m / 11" - 7'10"
3.81 m / 150"	4.5 m / 14'9"	9.0 m / 29'6"	-0.94 m - 2.81 m / 3'1" - 9'3"	0.34 m - 2.99 m / 1'1" - 9'10"
5.08 m / 200"	6.0 m / 19'8"	12.0 m / 39'4"	-1.25 m - 3.74 m / 4'1" - 12'3"	0.45 m - 3.99 m / 1'6" - 13'1"

Projection distance (screen aspect ratio 4:3)

Projection size (4:3) Diagonal length	Projection distance (L)		Height from the edge of screen to centre of lens (E)	Width from the right edge of screen to centre of lens (W)
	Min (Wide)	Max (Telephoto)		
1.01 m / 40"	1.5 m / 4'11"	2.9 m / 9'6"	-0.30 m - 0.91 m / 11.8" - 3'	0.08 m - 0.73 m / 3.1" - 2'5"
1.52 m / 60"	2.2 m / 7'3"	4.3 m / 14'1"	-0.45 m - 1.37 m / 1'6" - 4'6"	0.12 m - 1.09 m / 4.7" - 3'7"
2.03 m / 80"	3.0 m / 9'10"	5.8 m / 19'	-0.60 m - 1.82 m / 2" - 6"	0.16 m - 1.46 m / 6.3" - 4'9"
2.54 m / 100"	3.7 m / 12'2"	7.3 m / 23'11"	-0.76 m - 2.28 m / 2'6" - 7'6"	0.20 m - 1.82 m / 7.9" - 6"
3.81 m / 150"	5.6 m / 18'4"	11.0 m / 36'1"	-1.14 m - 3.42 m / 3'9" - 11'3"	0.30 m - 2.74 m / 11.8" - 9"

**NOTE:** The values of L shown above vary due to characteristics of the zoom lens. Images may slightly distort due to characteristics of the zoom lens when the zoom lens is set to the minimum throw distance.

Calculation of the projection distance

For a screen size different from the above, use the equation below to calculate the projection distance.

16 : 9	minimum	$L (m) = (\text{diagonal screen size in inches}) \times 0.0302 - 0.04$
	maximum	$L (m) = (\text{diagonal screen size in inches}) \times 0.0604 - 0.05$
4 : 3	minimum	$L (m) = (\text{diagonal screen size in inches}) \times 0.0371 - 0.04$
	maximum	$L (m) = (\text{diagonal screen size in inches}) \times 0.0739 - 0.05$

**NOTE:** The accuracy of calculated value by the formula shown above is  $\pm 5\%$ .

**Computer data compatibility**

This projector accepts up to 70 kHz horizontal scanning frequency and 150 MHz dot clock.

**NOTE:** The display resolution of this projector is 1920 x 1080 pixels. If the display resolution indicated in the above data does not match this resolution, the input signal will be converted to 1920 x 1080 pixels.

**List of Compatible Signals**

Display mode	Display resolution (dots) <sup>1</sup>	Scanning frequency		Dot clock frequency (MHz)	Picture quality <sup>2</sup>	Format
		H (kHz)	V (kHz)			
NTSC/NTSC4.43/PAL-M/PAL60	720 x 480i	15.7	59.9	-	A	VIDEO/S-VIDEO
PAL/PAL-N/SECAM	720 x 576i	15.6	50.0	-	A	VIDEO/S-VIDEO
525i (480i)	720 x 480i	15.7	59.9	13.5	A	COMPONENT
625i (576i)	720 x 576i	15.6	50.0	13.5	A	COMPONENT
525p (480p)	720 x 480	31.5	59.9	27.0	A	COMPONENT/HDMI
625p (576p)	720 x 576	31.3	50.0	27.0	A	COMPONENT/HDMI
750 (720)/60p	1,280 x 720	45.0	60.0	74.3	AA	COMPONENT/HDMI
750 (720)/50p	1,280 x 720	37.5	50.0	74.3	AA	COMPONENT/HDMI
1125 (1080)/60i	1,920 x 1,080i	33.8	60.0	74.3	AA	COMPONENT/PC/HDMI
1125 (1080)/50i	1,920 x 1,080i	28.1	50.0	74.3	AA	COMPONENT/PC/HDMI
1125 (1080)/24p	1,920 x 1,080	27.0	24.0	74.3	AA	COMPONENT/HDMI
1125 (1080)/60p	1,920 x 1,080	67.5	60.0	148.5	AA	COMPONENT/PC/HDMI
1125 (1080)/50p	1,920 x 1,080	56.3	50.0	148.5	AA	COMPONENT/PC/HDMI
VGA480	640 x 480	31.5	59.9	25.2	A	PC/HDMI
	640 x 480	37.5	75.0	31.5	A	PC
	640 x 480	43.3	85.0	36.0	A	PC
	640 x 480	72.1	138.0	62.3	A	PC
WIDE480	856 x 480	30.1	60.1	31.5	A	PC
SVGA	800 x 600	35.2	56.3	36.0	A	PC
	800 x 600	37.9	60.3	40.0	A	PC
	800 x 600	48.1	72.2	50.0	A	PC
	800 x 600	46.9	75.0	50.0	A	PC
	800 x 600	53.7	85.1	56.3	A	PC
WIDE600	1,072 x 600	37.2	59.9	51.4	A	PC
WIDE720	1,280 x 720	45.1	60.1	76.5	AA	PC
XGA	1,024 x 768	48.4	60.0	65.0	A	PC
	1,024 x 768	56.5	70.1	75.0	A	PC
	1,024 x 768	60.0	75.0	78.8	A	PC
	1,024 x 768	68.7	85.0	94.5	A	PC
	1,024 x 768	72.1	89.0	99.2	A	PC
WIDE768	1,280 x 768	45.3	56.5	76.2	A	PC
MXGA	1,125 x 864	64.0	71.2	94.2	A	PC
	1,125 x 864	67.5	74.9	108.0	A	PC
SXGA	1,280 x 1,024	64.0	60.0	108.0	A	PC
WIDE768-2	1,360 x 768	48.8	59.8	74.3	A	PC
SXGA60+	1,400 x 1,050	65.1	59.9	122.4	A	PC
WIDE800	1,280 x 800	49.7	59.8	83.5	A	PC
WIDE900	1,440 x 900	55.9	59.9	106.5	A	PC

1. The "i" appearing after the resolution indicates an interlaced signal.

2. The following symbols are used to indicate picture quality.

AA Maximum picture quality can be obtained.

A Signals are converted by the image processing circuit before picture is projected.

**Notes on Projector Placement and Operation**

The projector uses a high-wattage lamp that becomes very hot during operation. Please observe the following precautions.

1. Never place objects on top of the projector while it is operating.
2. Make sure there is an unobstructed space of 100 mm (3-15/16") or more around the projector's air intake openings.
3. If the projector is placed in a box or enclosure, ensure the temperature of the air surrounding the projector is between 0°C/32°F and 35°C/95°F. Also make sure the projector's intake and exhaust openings are not blocked. Take particular care to ensure that hot air from the exhaust openings is not sucked into the intake openings.

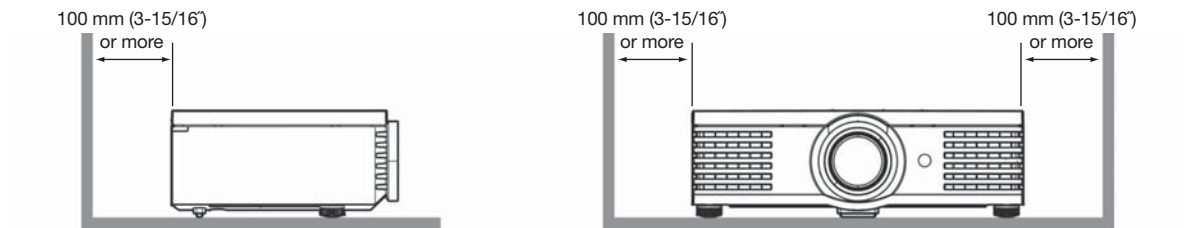

**Direction of Air Intake and Exhaust**

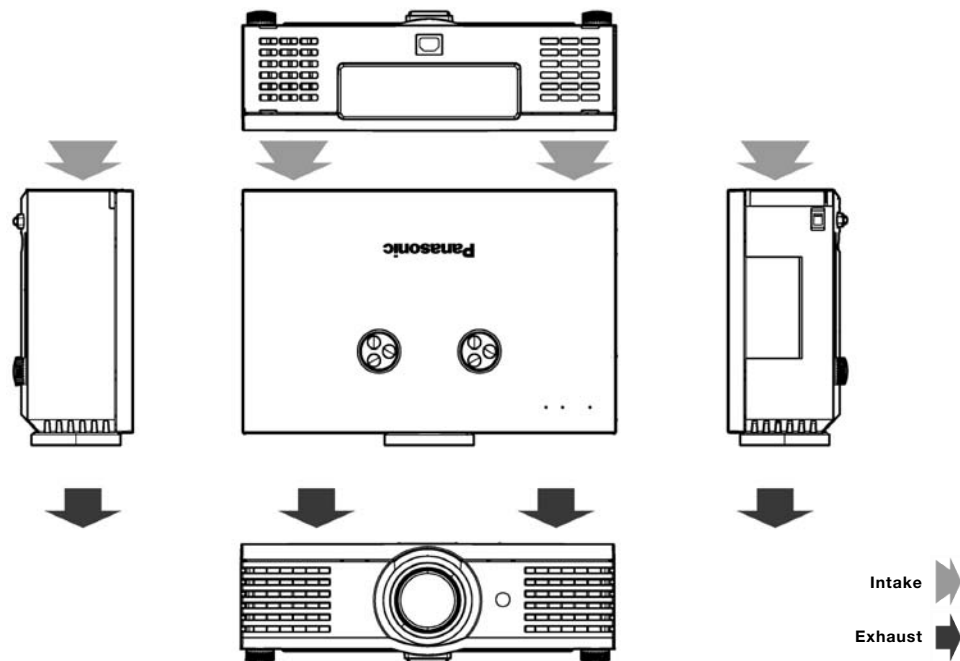

**Operating the Projector Continuously**

1. If the projector is to be operated continuously 10 hours or more, lamp replacement cycle duration becomes shorter.
2. The lamp replacement cycle duration becomes shorter if the projector is operated repeatedly for short periods.