

**ELMO**

**WARNING:**

■Unauthorized recording of copyrighted film/materials may infringe on the rights of copyright owners and be contrary to copyright laws.



**ELMO CO., LTD.**

6-14, Meizen-cho, Mizuho-ku,  
Nagoya, 467-8567, Japan

**OVERSEAS SUBSIDIARY COMPANIES**

**U.S.A.**

**Elmo Mfg. Corp.**  
1478 Old Country Road, Plainview, NY  
11803-5034  
Tel. (516) 501-1400 Fax. (516) 501-0429  
E-mail: [elmo@elmousa.com](mailto:elmo@elmousa.com)  
Web: <http://www.elmousa.com>

**Canada**

**Elmo Canada Mfg. Corp.**  
44 West Drive, Brampton, Ontario, L6T 3T6  
Tel. (905) 453-7880 Fax. (905) 453-2391  
E-mail: [info@elmocanada.com](mailto:info@elmocanada.com)  
Web: <http://www.elmocanada.com>

**Germany**

**Elmo (Europe) G.m.b.H.**  
Neanderstr 18, 40233 Düsseldorf  
Tel. (0211) 376051 Fax. (0211) 376630  
E-mail: [elmoeurope@AOL.com](mailto:elmoeurope@AOL.com)  
Web: <http://www.elmo.de/>

Printed in Japan  
6X1VIEN02 R3(A)

**VISUAL PRESENTER**

**EV-400AF**

**INSTRUCTION MANUAL**

**CCD**



**VISUAL  
TECHNOLOGIES**

[www.visualtec.com](http://www.visualtec.com)  
1620 Burnet Avenue  
Syracuse, NY 13206  
(315) 423-2000 tel  
(315) 423-0004 fax  
[contact@visualtec.com](mailto:contact@visualtec.com)

## IMPORTANT SAFEGUARDS

- **Read Instructions** – All the safety and operating instructions should be read before the appliance is operated.
- **Retain Instructions** – The safety and operating instructions should be retained for future reference.
- **Heed Warnings** – All warnings on the appliance and in the operating instructions should be adhered to.
- **Follow Instructions** – All operating and use instructions should be followed.
- **Cleaning** – Unplug this product from the wall outlet before cleaning. Do not use liquid cleaners or aerosol cleaners. Use a damp cloth for cleaning.
- **Attachments** – Do not use attachments not recommended by the product manufacturer as they may cause hazards.
- **Water and Moisture** – Do not use this product near water – for example, near a bath tub, wash bowl, kitchen sink, or laundry tub, in a wet basement, or near a swimming pool, and the like.
- **Accessories** – Do not place this product on an unstable cart, stand, tripod, bracket, or table. The product may fall, causing serious injury to a child or adult, and serious damage to the product. Use only with a cart, stand, tripod, bracket, or table recommended by the manufacturer, or sold with the product. Any mounting of the product should follow the manufacturer's instructions, and should use a mounting accessory recommended by the manufacturer.
- **Ventilation** – Slots and openings in the cabinet are provided for ventilation and to ensure reliable operation of the product and to protect it from overheating, and these openings must not be blocked or covered. The openings should never be blocked by placing the product on a bed, sofa, rug, or other similar surface. This product should never be placed near or over a radiator or heat register. This product should not be placed in a built-in installation such as a bookcase or rack unless proper ventilation is provided or the manufacturer's instructions have been adhered to.
- **Power Sources** – This product should be operated only from the type of power source indicated on the marking label. If you are not sure of the type of power supply to your home, consult your appliance dealer or local power company. For products intended to operate from battery power, or other sources, refer to the operating instructions.
- **Grounding or Polarization** – This product may be equipped with either a polarized 2-wire AC line plug (a plug having one blade wider than the other) or a 3-wire grounding type plug, a plug having a third (grounding) pin. The 2-wire polarized plug will fit into the power outlet only one way. This is a safety feature. If you are unable to insert the plug fully into the outlet, try reversing the plug. If the plug still fails to fit, contact your electrician to replace your obsolete outlet. Do not defeat the safety purpose of the polarized plug. The 3-wire grounding type plug will fit into a grounding type power outlet. This is a safety feature. If you are unable to insert the plug into the outlet, contact your electrician to replace your obsolete outlet. Do not defeat the safety purpose of the grounding type plug.
- **Power-Cord Protection** – Power-supply cords should be routed so that they are not likely to be walked on or pinched by items placed upon or against them, paying particular attention to cords at plugs, convenience receptacles, and the point where they exit from the product.
- **Lightning** – For added protection for this product during a lightning storm, or when it is left unattended and unused for long periods of time, unplug it from the wall outlet and disconnect the antenna or cable system. This will prevent damage to the product due to lightning and power-line surges.
- **Overloading** – Do not overload wall outlets, extension cords, or integral convenience receptacles as this can result in a risk of fire or electric shock.
- **A product and cart combination should be moved with care.** Quick stops, excessive force, and uneven surfaces may cause the product and cart combination to overturn.



■ **Object and Liquid Entry** – Never push objects of any kind into this product through openings as they may touch dangerous voltage points or short-out parts that could result in a fire or electric shock. Never spill liquid of any kind on the product.

■ **Service** – Do not attempt to service this product yourself as opening or removing covers may expose you to dangerous voltage or other hazards. Refer all servicing to qualified service personnel.

■ **Damage Requiring Service** – Unplug this product from the wall outlet and refer servicing to qualified service personnel under the following conditions:

- When the power-supply cord or plug is damaged.
- If liquid has been spilled, or objects have fallen into the product.
- If the product has been exposed to rain or water.
- If the product does not operate normally by following the operating instructions. Adjust only those controls that are covered by the operating instructions as an improper adjustment of other controls may result in damage and will often require extensive work by a qualified technician to restore the product to its normal operation.

■ If the product has been dropped or damaged in any way.

• When the product exhibits a distinct change in performance – this indicates a need for service.

■ **Replacement Parts** – When replacement parts are required, be sure the service technician has used replacement parts specified by the manufacturer or have the same characteristics as the original part. Unauthorized substitutions may result in fire, electric shock or other hazards.

■ **Safety Check** – Upon completion of any service or repairs to this product, ask the service technician to perform safety checks to determine that the product is in proper operating condition.

■ **Heat** – The product should be situated away from heat sources such as radiators, heat registers, stoves, or other products (including amplifiers) that produce heat.

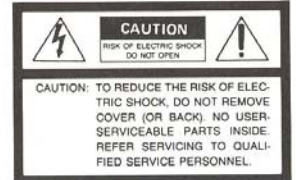

The lightning flash with arrowhead symbol, within an equilateral triangle, is intended to alert the user to the presence of uninsulated "dangerous voltage" within the product's enclosure that may be of sufficient magnitude to constitute a risk of electric shock to persons.



The exclamation point within an equilateral triangle is intended to alert the user to the presence of important operating and maintenance (servicing) instructions in the literature accompanying the appliance.

**WARNING:**  
TO REDUCE THE RISK OF FIRE OR ELECTRIC SHOCK, DO NOT EXPOSE THIS PRODUCT TO RAIN OR MOISTURE.

**INFORMATION**  
This equipment has been tested and found to comply with the limits for a Class A digital device, pursuant to Part 15 of the FCC Rules. These limits are designed to provide reasonable protection against harmful interference when the equipment is operated in a commercial environment. This equipment generates, uses, and can radiate radio frequency energy and, if not installed and used in accordance with the instruction manual, may cause harmful interference to radio communications. Operation of this equipment in a residential area is likely to cause harmful interference in which case the user will be required to correct the interference at his own expense.  
**USER-INSTALLER CAUTION:** Your authority to operate this FCC verified equipment could be voided if you make changes or modifications not expressly approved by the party responsible for compliance to Part 15 of the FCC rules.

## INTRODUCTION

Thank you for purchasing the ELMO Visual Presenter EV-400AF. To use the Visual Presenter properly, carefully read this operation manual before use. After reading the manual, keep it in a convenient place for quick reference.

The EV-400AF is the easy-to-operate and portable video presentation unit, equipped with a high-resolution CCD (Charge Coupled Device) camera. Featuring a 8X magnification zoom lens and a high accuracy auto focusing system, the EV-400AF captures all types of presentation materials, ex: 3-D objects, transparencies, to show or record through monitor TV, VCR, etc.

## BEFORE YOUR USE

Follow the instructions in this section to ensure safe operation. (Failure to follow these instructions may result in incorrect operation or malfunction of the Presenter.)

- \* Apply to the specified AC power source.
- \* Disassembling or modifying the Visual Presenter may result in electrical shock and machine malfunction.  
We are not responsible for any deterioration or failure of the Visual Presenter caused by disassembling or modifying by the user.
- \* Connecting or disconnecting the power cord should be carried out while firmly holding the plug.
- \* If the Presenter is left unused for a long period, disconnect the power cord for safety. Do not expose the Presenter to direct sunlight, high temperature, high humidity, or dust.
- \* Avoid storing or using the Presenter where vibration occurs.
- \* Install the Presenter in the following conditions.  
Temperature : 5°C~40°C (41°F~104°F)  
Humidity : 30%~85% (Avoid humid places, since humidity inside the products may cause failure of the set.)
- \* If the Presenter is used for purposes other than specified, we cannot guarantee its performance, service life or safety.
- \* Do not place or drop heavy objects or containers of liquid on the stage.
- \* Use only a soft, dry cloth for cleaning. Using benzine or thinner for cleaning may damage the coating or resin.
- \* Do not directly point the camera lens into the sun or similar since the camera will be damaged.
- \* The socket-outlet shall be installed near the equipment and shall be easily accessible.

## CONTENTS

Part names and functions .....	5
Setting up .....	9
Connection to monitor TV .....	10
* Connection to composite video-in terminal	
* Connection to S video-in terminal	
Operating procedures .....	11
* Simple steps for presenting printed materials	
* Simple steps for viewing transparencies as slide film	
* For use as a conventional video camera	
Stowing .....	12
Various functions .....	13
* Lighting	
* Input selection	
* Nega/posi conversion	
* Color/B&W selection	
* Zoom	
* Focus	
* White balance	
* Electronic shutter speed	
* Iris	
* Microphone	
* LCD monitor shoe	
External sync. adjustment .....	19
Manual remote .....	20
RS-232C specifications .....	21
* Set up	
* Cable connection	
* RS-232C connector specification (DSUB-9P)	
* Transmission mode	
* RS-232C terminal and DIP-SW position	
* List of transmission commands	
* Data format specifications	
Trouble shooting hints .....	25
Specifications .....	26

## PART NAMES AND FUNCTIONS

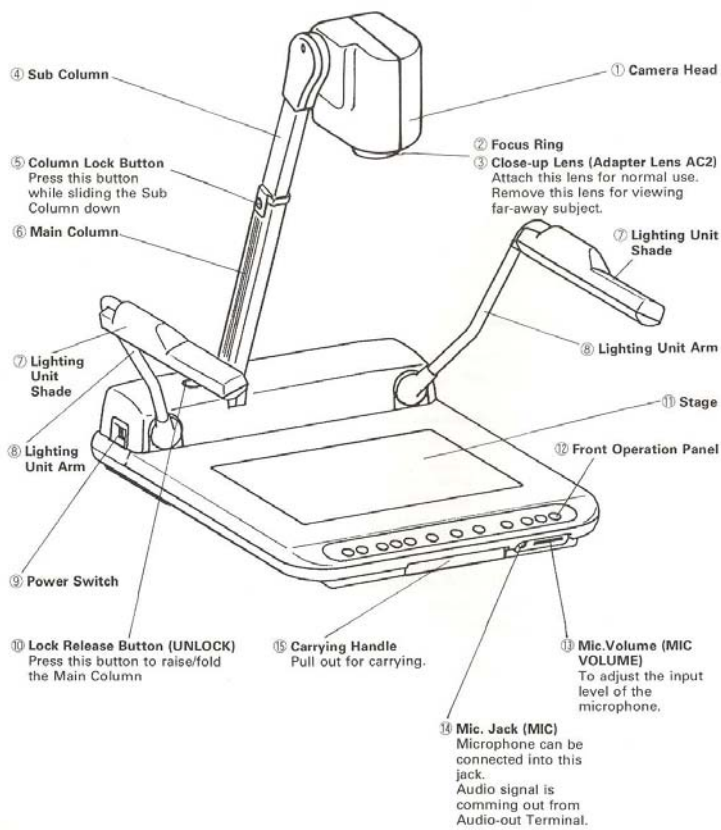

## ○ Front Operation Panel

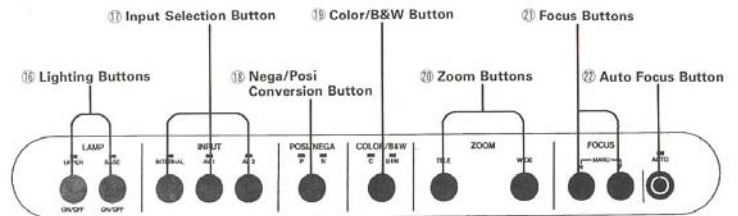

	Part Name	Function	Reference Page
16	Lighting Buttons	To turn on/off the light.	13
17	Input Selection Button	To change input line.	13
18	Nega/Posi Conversion Button	For viewing negative films.	14
19	Color/B&W Button	For viewing black and white material, such as documents.	14
20	Zoom Buttons	To adjust the image size.	14
21	Focus Buttons	To adjust focus (Powered).	15
22	Auto Focus Button	One-step auto focus for automatic focusing.	15

○Rear Panel

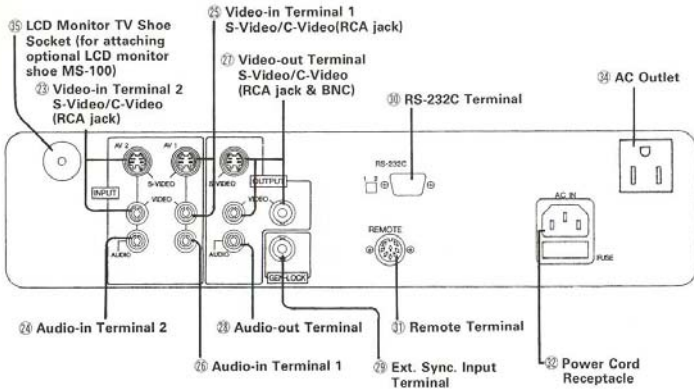

Part Name	Function	Reference Page
23 Video-in Terminal 2 S-Video/C-Video	Video signal is output from the video-out terminal 27 when input selection is set at AV2.	10
24 Audio-in Terminal 2	Audio signal is output from the audio-out terminal 28 when input selection is set at AV2.	
25 Video-in Terminal 1 S-Video/C-Video	Video signal is output from the video-out terminal 27 when input selection is set at AV1.	10
26 Audio-in Terminal 1	Audio signal is output from the audio-out terminal 28 when input selection is set at AV1.	
27 Video-out Terminal S-Video/C-Video	Connected to monitor TV, etc.	10
28 Audio-out Terminal	Audio-out terminal, Mic. (monaural), AV1, AV2 connected to monitor TV.	
29 Ext. Sync. Input Terminal	GEN-LOCK terminal for external synchronization.	19
30 RS-232C Terminal	Controlled by general purpose personal computer.	
31 Remote Terminal	Input terminal for external control signal.	20
32 Power Cord Receptacle	Connected to power cord connector.	
33		
34 AC Outlet	Max 400W	
35 LCD Monitor TV Shoe Socket	For attaching optional LCD monitor shoe MS-100	18

○Camera Head

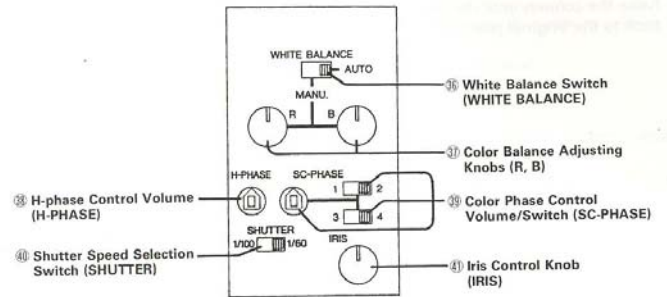

Part Name	Function	Reference Page
36 White Balance Switch	Select the mode for white balance adjustment. Set at [AUTO] for normal use.	16
27 Color Balance Adjusting Knobs	To adjust white balance for manual adjustment.	16
38 H-phase Control Volume	To adjust the horizontal sync. phase.	19
39 Color Phase Control Volume/Switch	To adjust the sub carrier phase.	19
40 Shutter Speed Selection Switch	To select 1/60 sec. or 1/100 sec. electronic shutter speed.	17
41 Iris Control Knob	To adjust the brightness of image. Set at middle position for normal setting.	17

## SETTING UP

1. Press the lock release button [UNLOCK] and raise the column.  
Raise the column until the lock release button gets back to the original position.

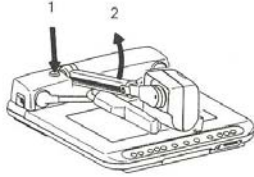

2. Extend the sub column until it is locked.
3. Adjust the camera head to the required position.



4. Set up the lighting units to stop positions.
5. Connect the power cord to the AC outlet.

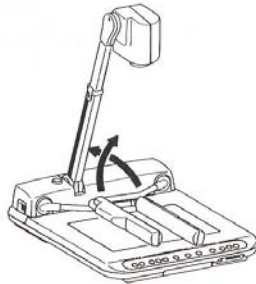

## CONNECTION TO MONITOR TV

Connect the supplied video cable to the video-out terminal of the Visual Presenter and to the video-in terminal of the monitor TV.

- Be sure to turn the power off before making connections (in order to protect the Visual Presenter and the other connected machines).
- Hold the cable plug firmly when disconnecting the video cable.

### ○ Connection to composite video-in terminal

Connection example for the device with the composite video-in terminal.  
Connect with the supplied video/audio cable with RCA pin plugs or a commercially-available BNC cable.  
(The Visual Presenter has one each of BNC and RCA jacks, and either jack is selectable.)

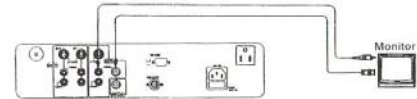

### ○ Connection to S video-in terminal

Connection example for the device with the S video-in terminal.  
S video-out terminal (mini DIN 4P) of the Visual Presenter is connected to the S video-in terminal of the TV monitor / video.  
For S video mode, use a commercially-available S video connection cable.  
If the device to be used is provided with a Y/C separate connector, a conversion adapter is necessary.

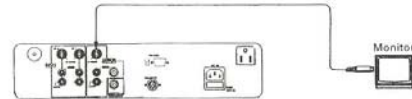

## OPERATING PROCEDURES

### Simple steps for presenting printed materials

1. Turn the power switch of the Visual presenter ON. (Connection to the monitor should be previously executed.)
  - \* Various functions of the Visual Presenter are initialized. The initial settings of those functions are displayed by their respective indicators.
2. Place the object on the stage. While observing the image on the TV monitor, adjust the zoom button to obtain the optimum size.
3. Press the auto focus button for focusing.
  - \* The covered area of the auto focus function is up to approx. 10 cm above the stage surface.



### Simple steps for viewing transparencies as slide film

1. Press the lighting button [BASE]. The [BASE] indicator lights on, and then the built-in baselight is turned ON.
2. Press the nega/posi conversion button, and the indicator shows [N] (Negative) mode.
3. When turning off the baselight, press the lighting button [BASE] again.



### For use as a conventional video camera

1. Remove the close-up lens when shooting the object at telephoto position.
2. Turn the camera head to horizontal position. This allows you to capture pictures on the wall, etc.

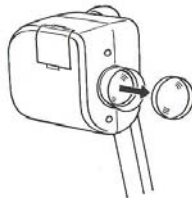

## STOWING

1. Turn the power switch OFF before disconnecting the power cord and the video cable.

**Note:** Be sure to hold the plug firmly when disconnecting. Do not pull the cord out carelessly.

2. Fold down the lighting unit arms.

**Note:** The arm, which is first folded down, should be turned and then the other as per the illustration so that two arms are closely located to the stage.

3. Turn the camera head to the illustrated position.

**Note:** Stow the camera head as per the illustration, or the stage surface or the lens may be damaged.

4. Press the column lock button, and shorten the sub column fully.

5. Press the lock release button [UNLOCK], and fold down the main column.

**Note:** The illustration shows the fixed folded-down position for the column. Do not further press the column with excessive strength.

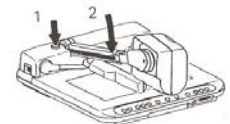

## VARIOUS FUNCTIONS

### ○Lighting

Lighting unit for viewing materials such as printed matter, 3-D object, and Baselight for viewing slide and negative film (transparencies) are built-in. With the lighting button pressed, the indicator flashes, and after a few seconds, the fluorescent lamps light on.

To turn the lamps off, press the lighting button again.

Select the [UPPER] or [BASE] mode.

(It is not possible to simultaneously use both the upper lighting unit and the base-light.)

It is advisable to use the upper lighting unit to obtain the clear image with better color rendering especially when the stage is not sufficiently illuminated by room lights or 3-D object is to be viewed.

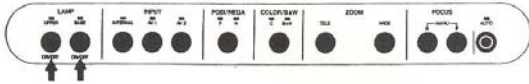

### ○Input selection

Images from two separate AV sources, such as a VCR and video camera, are selected to be projected on the monitor by pressing the input selection button.

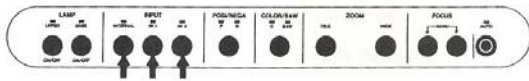

List of Video-In/Out Terminal Selections

Input	Output	Video-out terminal			Audio-out terminal
		S-VIDEO	C-VIDEO		
			RCA	BNC	
INTERNAL	Built-in camera	○	—	—	—
	Mic.	—	—	—	○
AV 1	Ext. video signal	○	—	—	—
	Ext. audio signal	—	—	—	○
AV 2	Ext. video signal	○	—	—	—
	Ext. audio signal	—	—	—	○

### ○Nega/posi conversion

This function is used to view negative film as positive images.

Press the nega/posi conversion button, and the indicator shows [N] (negative). Press the button again changes to normal [P] (positive) mode.

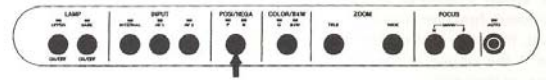

### ○Color/B&W selection

It is advisable to use this mode for viewing the B&W materials as documents, and clear image with no color blur is obtained.

For normal use, set to [C] (color) mode.

Pressing the color/B&W button changes to [B&W] or [C] mode in succession.

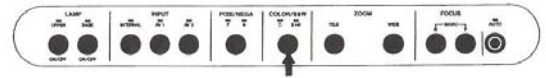

### ○Zoom

When the zoom button is pressed to select [TELE], the image gets larger. When the zoom button is pressed to select [WIDE], the image gets smaller.

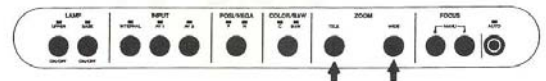

○Focus

(1) Auto Focus

- When the auto focus button is pressed, the indication lamp is turned ON and OFF during focusing.
- The Visual Presenter features a one-step auto focus function. Once focusing is completed, the auto focus function is released. Even if the object is moved, the focus remains unchanged.
- To focus the image with auto focus setting, set the zoom button at extreme telephoto position so that more accurate image can be obtained.
- It is difficult to automatically focus on an object under the following conditions. Select the focus mode to manual focus on objects in these conditions.
  - \* Object bearing little contrast.
  - \* Object with a fine repeated pattern such as lateral stripes, or a checkered pattern.
  - \* Bright object or one with reflecting strong light.
  - \* The background of the object is bright, or the contrast is too clear.
  - \* Picture plane itself is dark.
  - \* The positions of the objects are far and near.
  - \* Moving object.
- When using the manual focus during auto focusing, the auto focus function is cancelled.



(2) Powered Manual Focus

Press the focus button [N] or [F] for manual focusing. This function is used to view 3-D object of which any part can be focused.  
**Note:** The coverage area of manual focusing is up to approx. 10cm above from the stage surface.

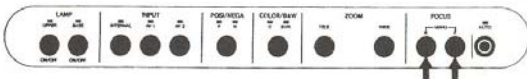

○White balance

(1) Full-Auto mode:

With the white balance switch at [AUTO] position, the camera automatically adjusts to the color temperature and adjusts the white balance. The camera will then automatically follow the change in color temperature of the object. Set [AUTO] position for normal use.

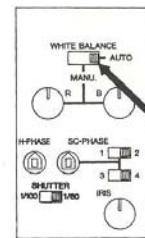

(2) Manual mode

With the white balance switch at [MANU.] position, turn the R (red) and B (blue) knobs while observing the white object on the monitor screen.

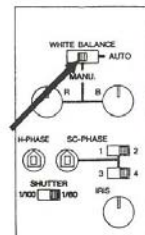

### ○Electronic shutter speed

Under the 50Hz electrical condition area, the flickering may appear under the fluorescent lamps, etc. with the EV-400AF set at "1/60" mode.

In this case, select "1/100" sec. shutter speed.

Leave the 1/60 sec. mode (original setting) for the use under the 60Hz area.

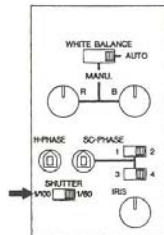

### ○Iris

Exposure is automatically compensated when the iris control knob is kept at middle position.

Exposure can be manually adjusted by turning the iris control knob.

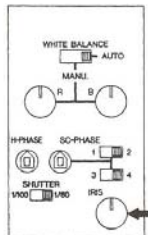

### ○Microphone

When using the video monitor with the audio-in terminal, connecting the microphone into the mic. jack allows the simultaneous output of the audio signal from the monitor speaker and video signals.

Adjust the mic. volume to obtain the optimum volume of the microphone.

The audio signal of the microphone is output from the audio out terminal regardless of position of the input selector.

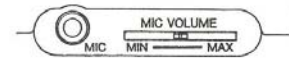

### ○LCD monitor shoe

The optional LCD monitor shoe, type MS-100 is available for attaching an LCD monitor (commercially-available) with a tripod screw hole onto the EV-400AF.

(Refer to the operation manual for the LCD monitor for connection.)

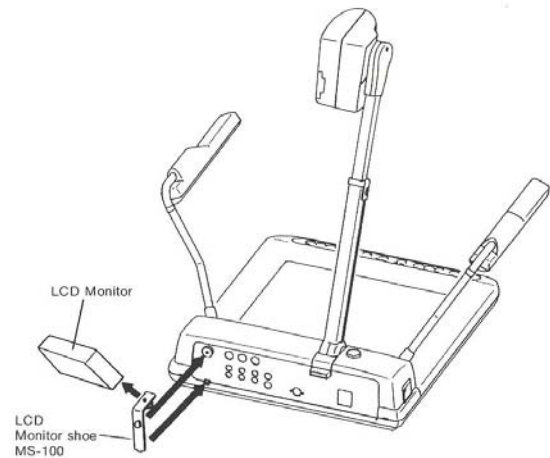

## EXTERNAL SYNC. ADJUSTMENT

This adjustment is necessary when images from several AV sources, such as the Visual Presenter, video cameras, and other equipment (including ELMO film-to-video converter TRV-35H, TRV-16G), are composed to be projected on a single monitor. Horizontal sync. position adjustment and sub carrier position adjustment are required to match the color phases of each image.

A video mixer is necessary to reproduce a composite image. The connection method differs depending on the type of the video mixer. Refer to the instruction manual of the respective video mixer for additional information on connection method.

### ● Horizontal sync. phase adjustment

This adjustment is used to adjust the horizontal phase when the Visual Presenter is subject to ext. sync. (GEN-LOCK). When adjusting the phase, use an adequate (-) screwdriver or the like.

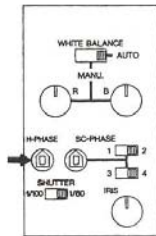

### ● Sub-Carrier Phase Adjustment

This adjustment is carried out if the color phase of the image output signal of the Visual Presenter is not appropriately adjusted to the base signal when overlapping images.

Set the color phase control switch for adjusting the color phase of the image to color phase of the base signal to bring each color phase as close as possible.

Fine adjusting by color phase volume is further carried out.

When adjusting the sub-carrier phase, use an adequate (-) screwdriver or the like.

SC-phase	0°	180°	270°	90°
Switch positions	1 2 3 4	1 2 3 4	1 2 3 4	1 2 3 4

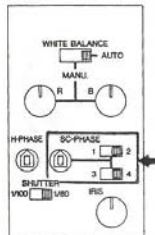

## MANUAL REMOTE

Terminal for remote control.

The remote receptacle comes with a DIN8P (DIN No. 45326) connector outlet. These functions will work when the relative contacts are shorted.

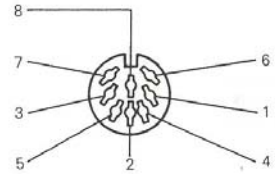

### ● Function between contacts

Close contact	Functions
1 & 8	Focus to FAR
2 & 8	to NEAR
3 & 8	Zoom to WIDE
4 & 8	to TELE
6 & 8	Auto Focus
Function keys	
7 & 8/1 & 8 ※	Baselight ON/OFF
7 & 8/2 & 8	Upper lighting ON/OFF
7 & 8/6 & 8	Input selection [Internal→AV1→AV2]

5 No Use (OPEN)

8 COMMON

※ 7 & 8/1 & 8 means, close contact #1 & #8 with close contact #7 & #8.

### ● Timing Diagram

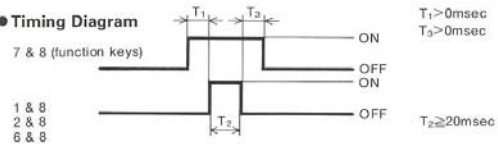

### ● Optional remote control

Elmo wired remote control RC-551, or Elmo wireless remote control RCW-552 are optionally available. However, please note that "Zoom size preset" of the remote control does not function when using with EV-400AV.

## RS-232C SPECIFICATIONS

The Visual Presenter can be operated with the personal computer (IBM/PC or compatible) with connecting it to the RS-232C terminal.

### Set up

1. Connect the Visual Presenter to the personal computer with the RS-232C connection cable (Optional).  
Refer to the following connection diagram. When using a commercially available RS-232C cable, make sure that it is connected as described below.
2. Start the personal computer to set the RS-232C mode same as that of the communication mode of the Visual Presenter.  
Refer to the instruction manual of the personal computer for setting the RS-232C mode.
3. Set the transmission speed same as that of the personal computer. Then turn the power ON.
4. Start the program of the personal computer to operate the Visual Presenter. Then open the communication line.
5. Controlling with RS-232C starts.

Note: Make sure to take the above steps for communication control.

### Cable connection

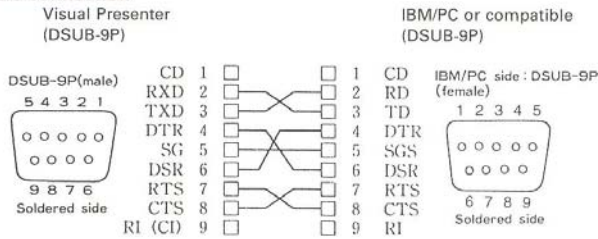

Note: If the connector cable is not correctly connected to the Visual Presenter and personal computer, no answer is obtained.  
Connect the connector cable correctly with screws for operation.

### RS-232C connector specification (DSUB-9P)

Pin No.	Code	Direction of data Visual Presenter ↔ PC	Comments
1	CD	—	CD : Carrier Detect
2	RXD	←	RXD : Received Data
3	TXD	→	TXD : Transmitted Data
4	DTR	→	DTR : Data terminal Ready
5	SG	—	SG : Signal Ground
6	DSR	←	DSR : Data Set Ready
7	RTS	→	RTS : Request To Send
8	CTS	←	CTS : Clear To Send
9	RI	—	RI : Ring Indicator

### Transmission mode

Half duplex start-stop sync. mode

Start bit : 1 bit

Data bit : 8 bit

Stop bit : 1 bit

Parity bit : none

X parameter : none

Baud rate

(Transmission speed) : 600, 1200, 2400, 4800 bps.....DIP-SW selection

### RS-232C terminal and DIP-SW position

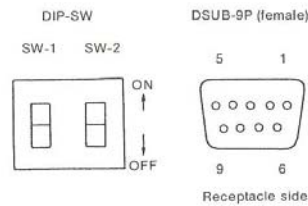

Baud Rate Setting  
(DIP-SW selection)

Baud Rate	SW-1	SW-2
600	OFF	OFF
1200	ON	OFF
2400	OFF	ON
4800	ON	ON

\* Factory set at: 4800 bps

Viewed from rear panel

## ○LIST OF TRANSMISSION COMMANDS

Function	Command	Parameter	Data	Comments
Lighting	PL	OFF=0 BASE=1 UPPER=2	<input type="checkbox"/> <input type="checkbox"/>	
Input Selection	AV	INT=0 AV1=1 AV2=2	<input type="checkbox"/> <input type="checkbox"/>	
Auto Focus	AF	0	<input type="checkbox"/> <input type="checkbox"/>	
Focus (Analog control)	MF	NEAR=+ FAR=-	<input type="checkbox"/> <input type="checkbox"/>	
Focus (Digital control)	FO	NEAR=+ FAR=- OFF=0	<input type="checkbox"/> <input type="checkbox"/>	Focus control.
Zoom (Analog control)	MZ	TELE=+ WIDE=-	<input type="checkbox"/> <input type="checkbox"/>	
Zoom (Digital control)	ZO	TELE=+ WIDE=- OFF=0	<input type="checkbox"/> <input type="checkbox"/>	Zoom control.
Nega/Posi	NP	POSI=0 NEGA=1	<input type="checkbox"/> <input type="checkbox"/>	
Color/B&W	CB	COLOR=0 B&W=1	<input type="checkbox"/> <input type="checkbox"/>	
Default	DF	0	<input type="checkbox"/> <input type="checkbox"/>	Initialize mode reset.
Status request	QS	0	<input type="checkbox"/> <input type="checkbox"/>	
ROM Version	QR	0	<input type="checkbox"/> <input type="checkbox"/>	ROM Version request.
Acknowledge check	SA	OFF=0 ON=1	<input type="checkbox"/> <input type="checkbox"/>	Select each command acknowledge.
Add CR command	SC	OFF=0 ON=0	<input type="checkbox"/> <input type="checkbox"/>	Add CR command after the acknowledge.

Note: "

 means transmitting SPACE [20H] twice.

## ○DATA FORMAT SPECIFICATIONS

This command is in accordance with the form of 1-command/1-packet.  
The next key input is not received until the one processing is executed.

### ● File open and file close

Communication will be carried out in ASCII code according to the following format.  
ENQ [05H] : Inquiry for connecting the line (PC→Visual Presenter)  
ACK [06H] : Sent upon normal acknowledgment (Visual Presenter→PC)  
NAK [15H] : Sent upon negative acknowledgment (Visual Presenter→PC)  
EOT [04H] : Sent upon end of the line (PC→Visual Presenter)  
ACK [06H] : Sent upon normal acknowledgment (Visual Presenter→PC)

### Serial communication line reset.

Push both [UPPER] lighting button and [BASE] lighting button, then serial communication line will be reset, terminal (Visual Presenter) will sent the DC1 signal to host computer.

### ● Transmit format (PC→Visual Presenter)

[STX]	command	parameter	data	[ETX]
02H	<input type="checkbox"/> <input type="checkbox"/>	<input type="checkbox"/>	<input type="checkbox"/> <input type="checkbox"/>	03H
			2×20H	

### Notes:

1. Make sure that the transmit format starts with STX (Start of Text) and ends with EXT (End of Text).
2. If the transmit format or command name is wrong, NAK (Negative Acknowledgement) is sent from the Visual Presenter as a result of failing to receive correctly.
3. If the send format is correctly sent, the Visual Presenter sends ACK (Normal Acknowledgement).

### ● Response data format

#### • Status request format

[STX]	Lighting	Input Selection	Nega/Posi	Color/B&W	[ETX]
<input type="checkbox"/>	<input type="checkbox"/>	<input type="checkbox"/>	<input type="checkbox"/>	<input type="checkbox"/>	<input type="checkbox"/>
02H					03H

example: each data will be corresponded with each command parameters.

#### • ROM version

[STX]								[ETX]
<input type="checkbox"/>	<input type="checkbox"/>	<input type="checkbox"/>	<input type="checkbox"/>	<input type="checkbox"/>	<input type="checkbox"/>	<input type="checkbox"/>	<input type="checkbox"/>	<input type="checkbox"/>
02H								03H

## TROUBLE SHOOTING HINTS

Symptom	Possible Cause/Countermeasure
No Images on TV monitor	<ul style="list-style-type: none"> <li>• Cable is not properly connected to the video-in terminal of monitor.</li> <li>• The power cord is disconnected from the wall AC outlet.</li> <li>• The plug is disconnected from the outlet.</li> <li>• Power is not turned on.</li> <li>• Zoom is set at Tele to display only white part of the material.</li> </ul>
Out of focus	<ul style="list-style-type: none"> <li>• The object is too close to the lens. Check if it does not stand higher than 10cm from the stage surface.</li> <li>• The 3-D object is not focused unless the sub column (camera head) is extended.</li> <li>• The object on the stage is not focused if the close-up lens is removed from the camera head.</li> <li>• Zoom is set at Tele after focusing at Wide angle.</li> <li>Focus on the point of max. Tele.</li> <li>• It is difficult to automatically focus on such objects as referred on page 15.</li> </ul>
The lamp is not quickly turned on.	<ul style="list-style-type: none"> <li>• This is caused by the built-in safety circuit for protecting the lamp. This is not a fault.</li> </ul>
Image is too dark.	<ul style="list-style-type: none"> <li>• The iris control knob (IRIS) is set at dark side (CLOSE).</li> <li>• The illumination is not sufficient. Use the lighting unit.</li> </ul>
Input selection can not be made.	<ul style="list-style-type: none"> <li>• Inputting to S-video while connecting output of C-video to the monitor or vice versa.</li> </ul>
The playback image is striped looking.	This is caused by the interference strips between the dot of printed material and the scanning line. This is not a fault.
Flickers on TV monitor.	Set the shutter speed to 1/100 to reduce flickers.

\*If trouble still persists even after checking the above, consult your dealer or an authorized Elmo service center.

## SPECIFICATIONS

### General

Power source : 120V AC 60Hz  
 Power consumption : 35W  
 AC outlet : Provided 1 pce max. 400W (3.2A)/Unswitched  
 Outside dimensions : 690mm (W) 545mm (D) 653mm (H) -when set up  
 450mm (W) 545mm (D) 203mm (H) -when folded  
 Weight : 8.5kgs

### Optics

Lens : F1.4~2.1, f=8.5mm~68mm  
 Shooting area : 320mm×240mm max. (WIDE-Scan100%)  
 Limit of focus adjustment : at the range of stage surface~10cm from the stage surface (with column extended position and with close-up lens)  
 ~-1.2m (without close-up lens)

### Zoom

### Focusing

### Iris

### Lighting

#### Upper lighting unit

: High frequency lighting method. Fluorescent lamp 6W×2,  
 (type: FHL6EX-N/CODE # 9356)

#### Built-in baselight

: High frequency lighting method.

### Video

Television system : NTSC compatible  
 Image pick-up element : 1/2" Interline-transfer CCD  
 Picture element : 811 (H)×508 (V)  
 Sync.system : Internal/External sync. (automatic changeover)  
 Resolution : More than 450 TV lines (V signal with horizontal)  
 More than 350 TV lines (Vertical)

### S/N ratio

: 46 dB  
 Output signal : C-video VBS 1.0 Vp-p/75Ω unbalanced  
 S-video Y 0.714 Vp-p/75Ω unbalanced  
 C 0.286 Vp-p/75Ω unbalanced

### Ext. sync. input condition

: C-video VBS (75Ω unbalanced)  
 Sync: 0.286V±0.1V, Burst: 0.286V±0.1V  
 (against NTSC standard) H±20ppm, SC±50ppm

### Ext. sync. frequency range

### H-phase adjustment

### SC-phase adjustment

### Electronic shutter

### White balance

### Nega/posi conversion

### Color/B & W selection

### Input selection

### Input terminal

: 1/60 sec. or 1/100 sec.  
 Full auto/Manual  
 Built-in (C-video, S-video)  
 Built-in (C-video, S-video)  
 3 systems (Internal/AV1/AV2)  
 C-video input (RCA jack/75Ω unbalanced)×2  
 S-video input (Mini DIN 4P connector/75Ω unbalanced)×2  
 Ext. sync. input (BNC connector/75Ω unbalanced)×1  
 Mic. input (φ 6.3mm jack/applicable impedance 600Ω, -65dB)×1  
 Audio input (RCA jack/applicable impedance 10KΩ or more, -10dB)×2

### Output terminal

: C-video output (RCA jack/75Ω unbalanced)×1  
 (BNC connector/75Ω unbalanced)×1  
 S-video output (Mini DIN 4P connector/75Ω unbalanced)×1  
 Audio output (RCA jack/applicable impedance 10KΩ or more, -10dB)×1  
 RS-232C (DSUB-9P)×1  
 Manual remote (DIN 8P)×1

### Supplied accessories

Power cord : ×1  
 Video-audio cable : ×1  
 Close-up lens (Adapter Lens AC2) : ×1  
 Operation manual : ×1  
 Dust Cover : ×1

\*The design and specifications are subject to change without prior notice.  
 Weight and dimensions are approximate.